



GLOBAL BRAND GUIDELINES

Implementing the
Valley[®] Irrigation
Brand

Welcome to the Valley® Brand Guidelines

Rich in history and brand equity, Valley® Irrigation is committed to presenting a globally unified brand at every level—from corporate and dealer communication to partner development and beyond.

These guidelines are for everyone who contributes to the presence of our brand and for all who communicate under the Valley Irrigation banner. You and your established name represent Valley, along with its values and marketplace position. Everything our customers associate with Valley, they will expect from you.

As our partner, you profit from the strength created by the Valley brand. Adopting these guidelines will strengthen both your position in the marketplace and our global brand.

These guidelines are not meant to be restrictive. They are to provide a formal structure that allows for cohesive, consistent brand application that continues to build further equity in a powerhouse brand.

Welcome to Valley Irrigation.



Amy Frohloff
Marketing Director

Valmont® Industries, Inc.

Valmont® Industries, Inc., is a leading producer and distributor of products for the infrastructure and agriculture markets.

Valmont began in 1946 when our founder, Robert B. Daugherty, combined his \$5,000 savings with a wholehearted belief that business could and should be done better. Since that modest start more than 70 years ago, our company has grown into an international leader in engineered products and services for infrastructure and water-conserving irrigation equipment for agriculture.

At Valmont, we are committed to **Conserving Resources. Improving Life®**. This can be seen in all aspects of our business. Our lighting and traffic structures guide the way. Our wireless communications towers help keep people connected. The electricity used in millions of homes and businesses around the world is delivered through our power utility structures. Our irrigation systems help ag producers grow the food that feeds the world. The coatings we offer add life and aesthetic value to metal products while helping to create a more sustainable future.

Valmont operates in four primary business segments: Engineered Support Structures (ESS), Utility Support Structures (Utility), Irrigation and Coatings. Our company manufactures its products in over 80 different facilities spread across six continents, and our products are available in over 100 different countries. Valmont is publicly traded on the New York Stock Exchange under the symbol (VMI).

Valmont employees are passionate about the products we make. We pride ourselves on being people of integrity who excel at delivering optimal results. Our products are the cornerstone of our success. We pursue opportunities for growth by taking our products and processes to new markets, introducing new products to regions where we have a presence and continually improving our services to ensure that Valmont solutions are second to none.



TABLE OF CONTENTS

| | | | | | |
|-----------|--|-----------|-----------|-------------------------------------|-----------|
| 01 | BRAND BASICS | 5 | 04 | TEMPLATES | 50 |
| | Overview | 6 | | Branded PowerPoint | 51 |
| | Brand Values | 7 | | Internal Communications | 52 |
| | Valley Irrigation Brand | 8 | | Bulletins | 53 |
| | Valley Irrigation Logo | 9 | 05 | SIGNAGE & FLAGS | 54 |
| | Logo Usage | 11 | | Valley Outdoor Signage | 55 |
| | Logo Sizes | 14 | | Awnings | 67 |
| | Logo Usage on Apparel & Promotional Materials | 16 | | Vehicle Identification | 69 |
| | Logo Spacing & Positioning | 18 | | In-Store Retail Signage | 73 |
| | Valley Tagline Usage | 20 | | Flag Display Policy & Ordering | 74 |
| | Valley “V” Usage | 21 | 06 | PRODUCT LITERATURE | 76 |
| | Valley Irrigation Color Palette | 22 | | Literature | 77 |
| | Valley Irrigation Typeface | 23 | 07 | DIGITAL GUIDELINES | 78 |
| | Product Name Guidelines | 28 | | Social Media Guidelines | 79 |
| | Product Photography | 33 | | Social Media Policy | 80 |
| | Brand Voice | 34 | | Posting to Social Media | 81 |
| | Brand Description | 35 | 08 | PUBLIC RELATIONS | 82 |
| | Valmont Irrigation Logo Usage | 37 | | Public Relations | 83 |
| 02 | TRADEMARKS & COPYRIGHTS | 38 | | Press Release Template | 84 |
| | Proper Usage of Trademarks | 39 | | Story Pitches & Media Alerts | 85 |
| | Trademarks & Registration Marks | 41 | | Media Alert Template | 86 |
| | Usage of Brand & Product Names in Text | 42 | 09 | CONCLUSION | 87 |
| 03 | IDENTIFICATION | 43 | | Brand Summary | 88 |
| | Letterhead Guidelines | 44 | | | |
| | Envelope Guidelines | 45 | | | |
| | Business Card Guidelines | 46 | | | |
| | Email Signature Guidelines | 48 | | | |
| | Voicemail Guidelines | 49 | | | |

01

BRAND BASICS

VALLEY. IRRIGATION BRAND GUIDELINES

Overview

The Valley Irrigation brand is one of our most valuable assets. It is how we are recognized and valued by our most important audiences—growers, dealers, farm managers, partners, investors and employees. Every time the Valley Irrigation name or logo is used, we are making a statement about who we are and what we stand for.

Although this document provides guidance on the use of the brand's visual and written applications, how they are implemented is most important—and that is up to you. To ensure a consistent brand experience, we need your help. You are the steward of this brand. These guidelines provide you with the tools to begin.

Brand Positioning

Valley is the global leader in irrigation because we offer growers an unequalled combination of superior equipment and unmatched dealer support. We have succeeded in becoming the industry leader because our growers have succeeded. Since day one, Valley solutions and Valley relationships have been built the same way: infused with personal commitment and made to last.



Brand Values

What do we stand for?

Valley sets the foundation for how customers perceive our brand by our five brand pillars. They serve as the cornerstone from which all our communications and interactions flow. They create the expectation for customer connection and allow our customers to experience our brand promise firsthand.

Reliable

Authentic, Stands the Test of Time, The One You Can Count On, Trustworthy

Durable

Solid Product – Solid Partnership, Enduring Strength, Toughness, Deep-Rooted

Precise

Accurate, Diligent, On the Mark

Advanced

Future Focused, Positive Gains, Knowledgeable Insight, Progressive

Responsive

Dependable, Genuine, Perceptive

Valley Irrigation Brand

The basic elements of the Valley brand include:

- logo
- colors
- typeface
- brand voice
- photography

Through every form of communication and experience – through the solutions we sell, the service we provide, how we act and what we say. Everything we do has a direct impact on how the world perceives us.

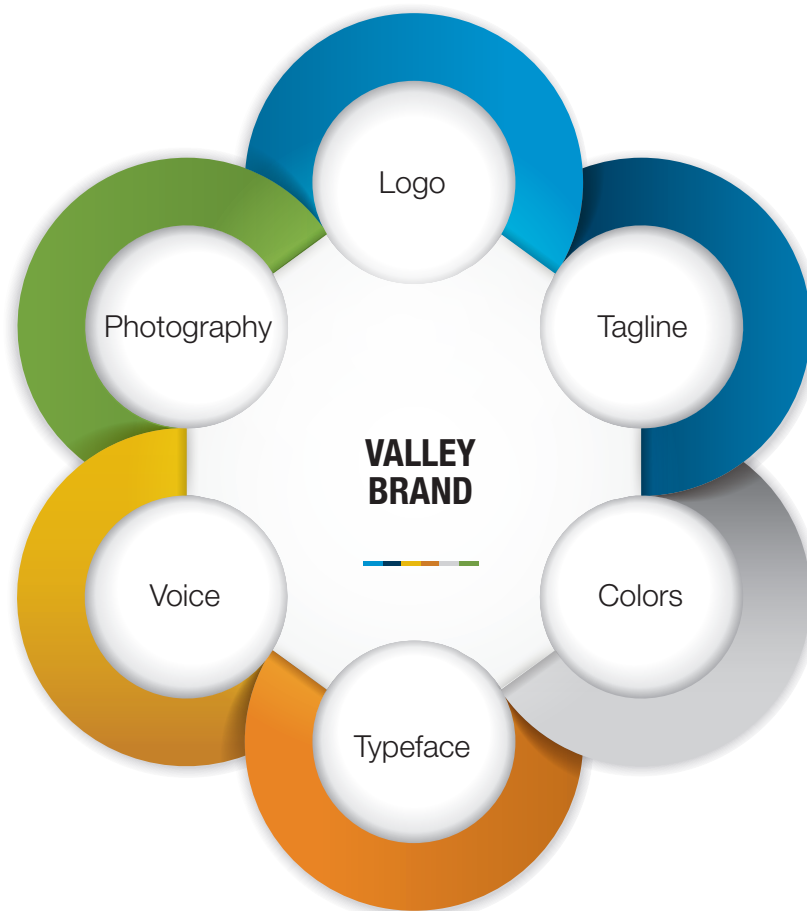

The Leader in Precision Irrigation®

Valley Logo

The Valley logo is the main asset of the Valley brand. To ensure its effectiveness and preserve logo integrity, it is important to avoid misusing or modifying the logo artwork.

The logo includes the trademark “V” carefully and precisely paired with the stylized “Valley” logotype and registered ®. To prevent any misuse, only use approved logo artwork and avoid adding effects that change its appearance in any way. The variations and mistakes, however small, will reduce the impact of the brand.

The Valley logo can only be used in Valley blue, black or reversed out in white. **Never use the logo with the color red.** Tone-on-tone logos on apparel, or silver signs are acceptable exceptions. Any other uses must be approved by the Strategic Marketing Team first.

Always use the most recent, high-quality versions of the logos.

Download the approved logos from valleyirrigation.com/brand.

Preferred Use

Horizontal logo



Horizontal logo with tagline



The Leader in Precision Irrigation.

Vertical logo



Vertical logo with tagline



The Leader in Precision Irrigation.

Acceptable Variations



The Leader in Precision Irrigation.



Important Notice:

If the logo is misused, it will be the responsibility of the party who created the materials to immediately rectify at its cost. In the event of unauthorized use, Valley will assert its right to claim legal action.

Valley - A Valmont Company Logo

The Valley - A Valmont Company logo is another logo option available. This logo should be used for the following marketing materials:

- Valley Company Stationery
- Valley Company PowerPoint Template
- Valley Business Cards
- Valley Corporate Websites

To prevent any misuse, only use approved logo artwork and avoid adding effects that change its appearance in any way. The variations and mistakes, however small, will reduce the impact of the brand.

The Valley - A Valmont Company logo can only be used in Valley blue, black or reversed out in white. Any other uses must be approved by the Strategic Marketing Team first.

Download the approved logos from valleyirrigation.com/brand.



A **valmont**  COMPANY

Using the Valley Logo

While not an exhaustive list, the examples shown here demonstrate logo misuses that undermine a consistent brand identity. The logo and tagline cannot be redrawn, re-typeset or modified in any way, under any circumstance.

Unacceptable Usage



Do not integrate the logo with your company name.

Dealership ABC



Do not use the logo elements separately or integrate with a different tagline.



Do not apply different colors to the elements of the logo.



Do not alter the proportions or positioning of the logo elements. Do not change the positioning or typeface of the Valley tagline.



Do not change the type weight or scale/positioning of the tagline.



Do not change the tagline in any way.



Do not use tints or shades of colors.



Do not recreate the logo using another typeface.



Do not use old versions of the logo or logo tagline.



Do not add special effects, such as bevel, drop shadow or glow.
(If this usage is necessary based on created elements the Valley Strategic Marketing Team must provide approval before use.)



Do not alter the approved colors in any way.



Do not outline the logo.

Using the Valley Logo

Unacceptable Usage

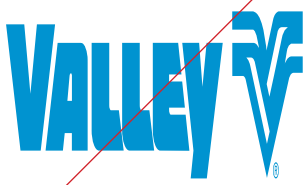

Do not skew or stretch the logo.



Do not use any part of the logo to create a new logo.

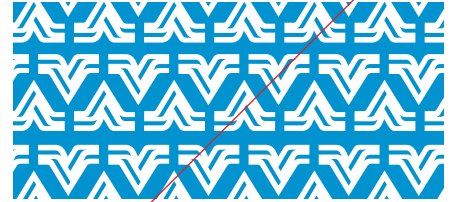

Do not use the Valley "V" trademark as part of a pattern or graphic.



Do not rearrange the elements of the logo.



Do not use the Valley logotype without the "V" trademark.



Do not place the logo on a distracting background.



Do not place the logo in a box on an image.



Always ensure the logo is positioned on a background offering sufficient contrast to maintain visual clarity. When the logo appears on an image, ensure that it is positioned on an area light enough (or dark enough, if using reverse version) to ensure maximum clarity.



Always ensure the logo is positioned on a background offering sufficient contrast to maintain visual clarity.



Do not scan the logo, copy/paste from an Internet application or use the logo with poor resolution.



A modifier or reference to any dealership should never be added to the logo.

Using the Valley Logo

Unacceptable Usage

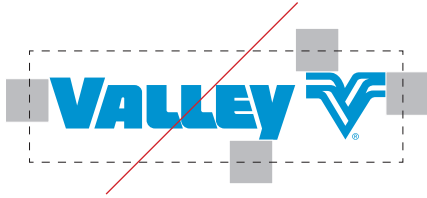

Do not ignore the minimum clearance zone (see page 17).



Do not add a business, product or location name to the Valley logo.



Do not put any other identities under the Valley logo, unless it is a Valley brand/company and is approved by the Strategic Marketing Team.

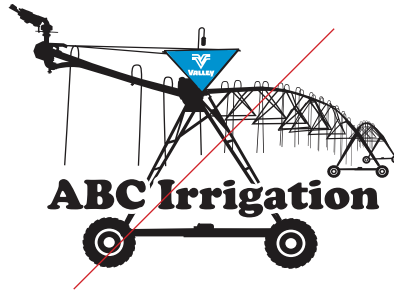

While using a generic pivot image in your logo is permitted, never use a pivot that incorporates the Valley logo, Valley V, Valley signage or Valley blue within it.

Incorrect: Check out these new solutions from 

Correct: Check out these new solutions from Valley Irrigation.

Do not use the logo in a statement or sentence, instead spell out the company name, Valley Irrigation.

Important Notice:

If the logo is misused, it will be the responsibility of the party who created the materials to immediately rectify at its cost. In the event of unauthorized use, Valley will assert its right to claim legal action.

Valley Logo Sizes: Digital

Use of all logos must follow all of the logo guidelines outlined in the Brand Basics section. Logos used in websites, social media and digital applications must use the following additional specifications:

- 72 DPI
- RGB color mode
- The “Valley Blue” must use the hexadecimal color number = #0093D0
- .jpg, .gif, .png or .svg file format
 - If the logo is being used against a white background, a .jpg or .gif is recommended
 - If the logo is being used against a dark or non-white background, a .png with a transparent background is recommended
 - If the logo is being used on a website, a .svg is recommended

Size Guidelines

Valley Horizontal Logo with Tagline

- Minimum required width – 175 pixels
- Maximum recommended width – 300 pixels

Valley Vertical Logo with Tagline

- Minimum required width – 150 pixels
- Maximum recommended width – 250 pixels

Valley Horizontal Logo without Tagline

- Minimum required width – 75 pixels
- Maximum recommended width – 300 pixels

Valley Vertical Logo without Tagline

- Minimum required width – 50 pixels
- Maximum recommended width – 200 pixels

North America Performance Logos

- Minimum required width – 250 pixels
- Maximum recommended width – 350 pixels

Without tagline



75 pixels width minimum



50 pixels width minimum

With tagline



The Leader in Precision Irrigation.

175 pixels width minimum



The Leader in Precision Irrigation.

150 pixels width minimum

Valley Logo Sizes: Print

The Valley Irrigation logo is the primary asset of the Valley Irrigation brand. To ensure its effectiveness and preserve the logo integrity, it is important to avoid misusing or modifying the logo artwork.

To ensure legibility, the Valley Irrigation logo should never be reproduced smaller than the minimum size shown here.

Minimum Size Print Logo Usage:

Minimum size without tagline



.75" width minimum



.5" width minimum

Minimum size with tagline



1.5" width minimum



The Leader in Precision Irrigation.

1.25" width minimum

Logo Usage on Apparel & Promotional Materials

Embroidery Logo Usage

Logo can be embroidered in tone-on-tone colors to represent the Valley Irrigation color palette (see page 21). Otherwise the logo should be embroidered in black or white.

Without tagline

Preferred colors are white, black, gray or Valley blue. **Red or any shade of red is never allowed.** Because the ® is too small to be embroidered legibly, it is removed from the logo in this instance.



(tone-on-tone example)



Exception of Embroidery

If you are embroidering the Valley Irrigation logo on apparel and promotional materials, you may use the variation of the Valley Irrigation logo that does not include the registration mark ®. In this case, contact the Valley Marketing Team at valleybrand@valmont.com to request a logo without the registration mark. Modifying a logo file, or asking a vendor to do so, is not permitted.

Logo Usage on Apparel & Premiums

Correct usage of the Valley logo on apparel and accessories is essential in maintaining the Valley brand.

As individuals who create Valley clothing and premium gifts, you are uniquely positioned to ensure the Valley brand is consistent and impactful on all items distributed to customers and employees. Here are a few things to keep in mind when creating Valley-branded items.

The Valley logo is allowed in various colors on promotional items; however, a **red Valley logo and red apparel/premiums are never allowed.**

Pre-selected premium items and apparel can be ordered through the dedicated website valleyirrigation.com/shop or by contacting:

The Valmont Store
P: +1 402.359.6624
store@valmont.com

Ordering items from a local supplier is also acceptable.

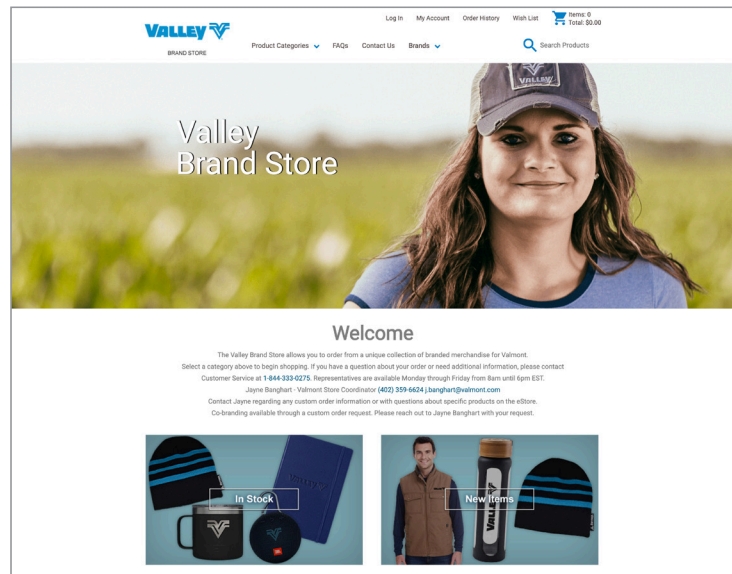

Spacing & Positioning the Valley Logo

To maximize the recognition and impact of our identity in all applications, surround the Valley logo with sufficient clear space – free of type, graphics and other elements that might cause visual clutter.

When the Valley logo is used, with or without the tagline, a clear spacing of “x” should be maintained around the perimeter of the logo (**where x = the height of “A” in Valley**). This means no other design elements or text should be positioned within this clear zone.

The logo also should not be positioned any closer than 2x to the outer margins or trim edge of the document.

There will be instances when space is at a premium and the preferred clear zone must be reduced. In these cases, contact the Strategic Marketing Team for approval.



Horizontal logo spacing without tagline

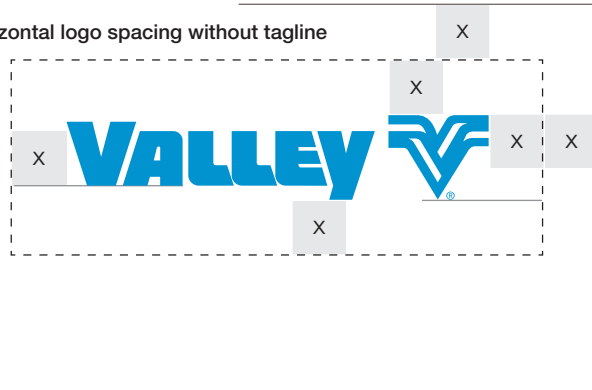

Horizontal logo spacing with tagline

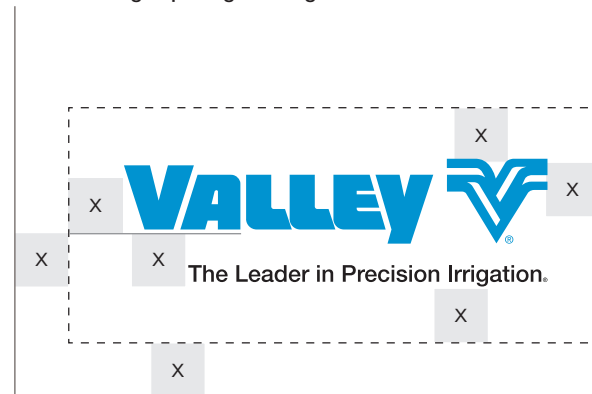

Vertical logo spacing without tagline

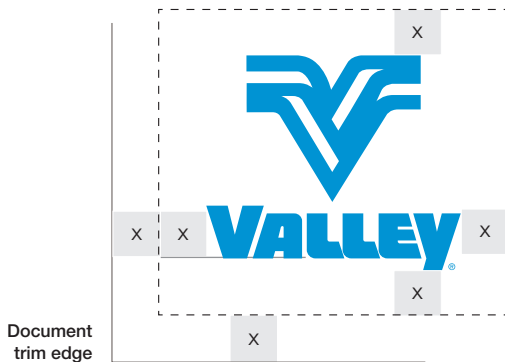

Vertical logo spacing with tagline

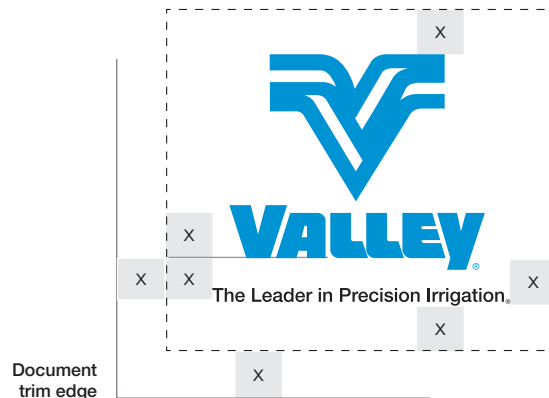

Spacing & Positioning the Valley Logo

Correct

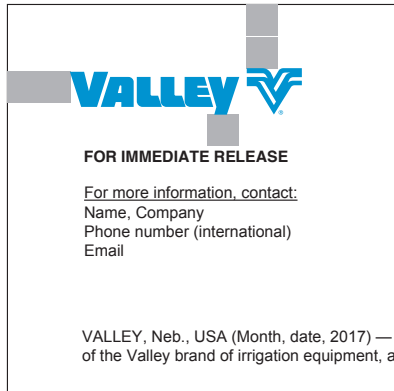

Incorrect

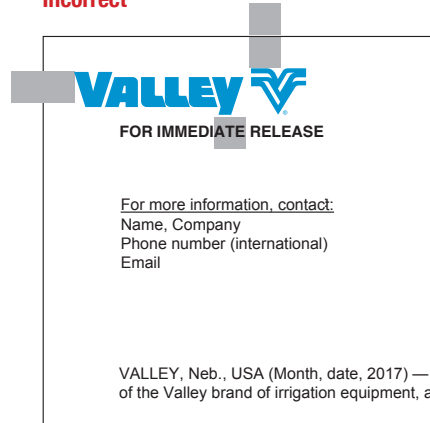

Do not place any text, logos or graphic elements too close to the Valley logo. See previous page for clear spacing guidelines.

Correct



Incorrect



Do not place any text, logos or graphic elements too close to the Valley logo. See previous page for clear spacing guidelines.

Valley Tagline Usage

The tagline ***“The Leader in Precision Irrigation®.”*** must always appear in black, unless it is appearing on a colored background, in which case it can appear in white as shown.

The logo and tagline cannot be redrawn, re-typeset or modified in any way, under any circumstance.

When the Valley logo is used with the tagline, a clear spacing of “x” should be maintained from the baseline of Valley to the baseline of the tagline. Please refer to the “Spacing and Positioning of the Valley Logo” page in this document for details regarding “x.”

The tagline may only be used by Valley, Valmont and by dealers when it is clearly correlated with the Valley brand. Dealers may not use the Valley tagline as their own or in such a way that it appears to be part of the dealer's brand.

Download the approved tagline usage from valleyirrigation.com/brand.

Horizontal usage



The Leader in Precision Irrigation.

Tagline aligns to the right side of the Valley logo

Vertical usage



The Leader in Precision Irrigation.

Tagline centers below the Valley logo

Alternate: On white



The Leader in Precision Irrigation.



The Leader in Precision Irrigation.

Alternate: On black



The Leader in Precision Irrigation.



The Leader in Precision Irrigation.

Valley "V" Usage

The Valley "V" trademark is associated with Valmont. Therefore, only the corporate office is permitted to use the "V" trademark as a separate or supportive design element.

If a need arises to utilize the Valley "V," it must comply with standards set forth by the corporate office **with approval of the Strategic Marketing Team.**

The primary usage of the Valley "V" trademark as a graphic element on its own will be visible in web applications and on products with space limitations, or in limited use as deemed appropriate by the Strategic Marketing Team.



IRRIGATION EXCHANGE

test@test.com // Logout

Test Environment
Production Environment

Your Test Access Key
51410719397340A6B393F141346A96E4

Your Test URL

| Core APIs | OADA Compliant APIs | URL |
|-------------------------------------|---------------------|--|
| Get all pivots configuration data | | http://72.165.239.116/DataInterface/DataInterface/Host/Machine.svc/Configuration/GetAllMachineData?AccessKey={accessKey}&ThirdPartyUserId={thirdPartyUserId} |
| Get all linear configuration data | | http://72.165.239.116/DataInterface/DataInterface/Host/Machine.svc/Configuration/GetAllLinearMachineData?AccessKey={accessKey}&ThirdPartyUserId={thirdPartyUserId} |
| Single linear configuration data | | http://72.165.239.116/DataInterface/DataInterface/Host/Machine.svc/Configuration/GetLinearMachineDataById?AccessKey={accessKey}&ThirdPartyUserId={thirdPartyUserId}&DeviceId={machineId} |
| Single pivot configuration data | | http://72.165.239.116/DataInterface/DataInterface/Host/Machine.svc/Configuration/GetMachineDataById?AccessKey={accessKey}&ThirdPartyUserId={thirdPartyUserId}&DeviceId={machineId} |
| All linear status data | | http://72.165.239.116/DataInterface/DataInterface/Host/Machine.svc/Status/GetAllLinearMachineStatus?AccessKey={accessKey}&ThirdPartyUserId={thirdPartyUserId} |
| Work order for standard linear stop | | http://72.165.239.116/DataInterface/DataInterface/Host/WorkOrderProcess.svc/WorkOrder/SendWorkOrderForStandardStop |

Submission Status: ● Approved Brand Standards I Agree Submission

Branding Information

Valley Irrigation Branding
The Valley logo is the main asset of the Valley brand. To ensure its effectiveness and preserve the logo integrity, it is important to avoid misusing or modifying the logo artwork. To prevent any misuse issues, use only approved logo artwork provided on this site and avoid adding effects that change its appearance in any way. Variations and mistakes, however small, will reduce the impact of the brand and may result in a denied submission.

[Access Valley Logos](#)

Registration Marks & Trademarks
Valley Logo
The Valley logo is registered to Valmont Industries. Anyone using the logo must always abide by the guidelines detailed in this document. The ® symbol is set in the artwork and must accompany the logo.

Irrigation Exchange Logo
The Irrigation Exchange logo is pending trademark registration to Valmont Industries. The ™ symbol is set in the artwork and must accompany the logo.

Account Information

Edit your contact information, Such as phone number.

| | |
|---|--|
| Email Address <input type="text" value="test@test.com"/> | First Name <input type="text" value="Test"/> |
| Password <input type="password" value="****"/> | Last Name <input type="text" value="User"/> |
| Confirm Password <input type="password" value="****"/> | Company Name <input type="text" value="Test Support"/> |
| Security Question <input type="text" value="What is your favorite sport?"/> | Phone Number <input type="text" value="123456789"/> |
| Security Answer <input type="text" value="TT"/> | Redirect Uri <input type="text"/> |

Receive email on grower grant

© Valmont Industries, Inc.

Web Example:
Valley Irrigation Exchange landing page

Valley ICON App



The Valley Color Palette

The Valley colors are an important part of our corporate image, differentiating us from other brands. Secondary colors are designed to prevent applications from becoming too monochromatic. These colors are intended to be used sparingly. Proper balance of these secondary colors and percentages must be given to ensure the “Valley Blue” remains the dominant color in all applications.

Consistent use of the approved color palette will maximize the impact and recognition of our communication materials in the marketplace — building brand equity.

Reproducing the Color Palette

When creating any printed, online or display materials, always use the color values shown on this page. To guarantee that colors are reproduced consistently, it is important to follow these color formulas.

For paint colors, please contact the Strategic Marketing Team for more information.

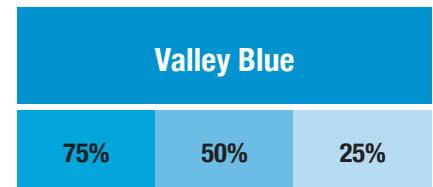

Valley Blue
75% **50%** **25%**
 CMYK: 100 / 10 / 0 / 10
 RGB: 0 / 147 / 208
 WEB: #0093D0
 PANTONE SPOT EQUIVALENT: Process Blue

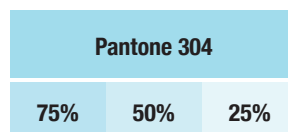

Pantone 304
75% **50%** **25%**
 CMYK: 35 / 0 / 2 / 0
 RGB: 154 / 219 / 232
 WEB: #9ADBE8

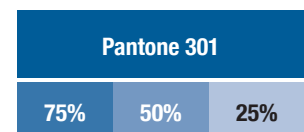

Pantone 301
75% **50%** **25%**
 CMYK: 100 / 51 / 0 / 34
 RGB: 0 / 75 / 135
 WEB: #004B87

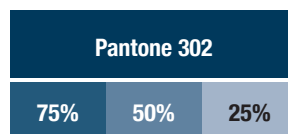

Pantone 302
75% **50%** **25%**
 CMYK: 100 / 32 / 0 / 68
 RGB: 0 / 59 / 92
 WEB: #003B5C



Pantone 110
75% **50%** **25%**
 CMYK: 0 / 20 / 100 / 8
 RGB: 218 / 170 / 0
 WEB: #DAAA00

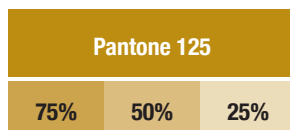

Pantone 125
75% **50%** **25%**
 CMYK: 0 / 31 / 100 / 25
 RGB: 181 / 133 / 0
 WEB: #B58500

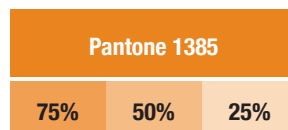

Pantone 1385
75% **50%** **25%**
 CMYK: 0 / 54 / 100 / 5
 RGB: 213 / 120 / 0
 WEB: #D57800

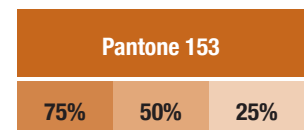

Pantone 153
75% **50%** **25%**
 CMYK: 0 / 57 / 100 / 17
 RGB: 190 / 106 / 20
 WEB: #BE6A14

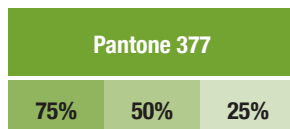

Pantone 377
75% **50%** **25%**
 CMYK: 41 / 0 / 100 / 22
 RGB: 122 / 154 / 1
 WEB: #7A9A01

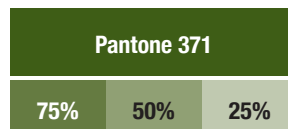

Pantone 371
75% **50%** **25%**
 CMYK: 40 / 10 / 98 / 59
 RGB: 84 / 98 / 35
 WEB: #546223

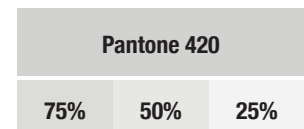

Pantone 420
75% **50%** **25%**
 CMYK: 18 / 13 / 10 / 0
 RGB: 199 / 201 / 199
 WEB: #C7C9C7

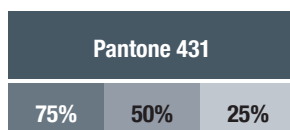

Pantone 431
75% **50%** **25%**
 CMYK: 63 / 45 / 34 / 25
 RGB: 91 / 103 / 112
 WEB: #5B6770

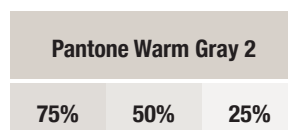

Pantone Warm Gray 2
75% **50%** **25%**
 CMYK: 16 / 15 / 16 / 0
 RGB: 203 / 196 / 188
 WEB: #CBC4BC

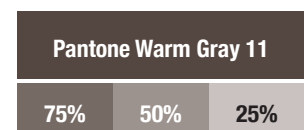

Pantone Warm Gray 11
75% **50%** **25%**
 CMYK: 46 / 47 / 50 / 30
 RGB: 110 / 98 / 89
 WEB: #6E6259

Valley Headline Typeface

The Forza type family is the preferred headline typeface for the brand. It should be used when designing all marketing materials. It is a clean font, easy to read and suitable for headlines.

If Forza is not available, any available Helvetica Neue or Helvetica typeface can be substituted.

Font Usage

Forza comes in a variety of styles and weights which allow for flexibility, but always take consistency into consideration in any application.

For the majority of uses, Forza Black is preferred. Other weights may be used when appropriate. For example, Forza Medium and Bold are used for second level subheads.

Please exercise restraint when using different styles and weights of the font to preserve the integrity and consistency of Valley printed materials. To ensure the text is readable, the minimum size used for this font should be 8 point.

Adding drop shadows, highlights and dimension to type in headlines and body copy is not allowed. Simple, clean, readable type is the goal.

Forza Black

**Aa Bb Cc Dd Ee Ff Gg Hh Ii Jj Kk Ll Mm
Nn Oo Pp Qq Rr Ss Tt Uu Vv Ww Xx Yy Zz
(.,:;!#\$\$%&@*) 0123456789**

Forza Light

Aa Bb Cc Dd Ee Ff Gg Hh Ii Jj Kk Ll Mm
Nn Oo Pp Qq Rr Ss Tt Uu Vv Ww Xx Yy Zz
(.,:;!#\$\$%&@*) 0123456789

Forza Book

Aa Bb Cc Dd Ee Ff Gg Hh Ii Jj Kk Ll Mm
Nn Oo Pp Qq Rr Ss Tt Uu Vv Ww Xx Yy Zz
(.,:;!#\$\$%&@*) 0123456789

Forza Medium

**Aa Bb Cc Dd Ee Ff Gg Hh Ii Jj Kk Ll Mm
Nn Oo Pp Qq Rr Ss Tt Uu Vv Ww Xx Yy Zz
(.,:;!#\$\$%&@*) 0123456789**

Forza Bold

**Aa Bb Cc Dd Ee Ff Gg Hh Ii Jj Kk Ll Mm
Nn Oo Pp Qq Rr Ss Tt Uu Vv Ww Xx Yy Zz
(.,:;!#\$\$%&@*) 0123456789**

Valley Body Copy Typeface

The Helvetica Neue LT Pro type family is the preferred body copy typeface for the brand. It should be used when designing all marketing materials. It is a clean font, easy to read and suitable for, body copy and tables.

If Helvetica Neue LT Pro is not available, any available Helvetica Neue or Helvetica typeface can be substituted.

Font Usage

Helvetica Neue LT Pro comes in a variety of styles and weights that allow for flexibility, but always take consistency into consideration in any application.

For the majority of uses, Helvetica Neue LT Pro Light is preferred. Other weights and styles, including italics, may be used when appropriate. For example, Helvetica Neue LT Pro Medium and Bold are used for second-level subheads. Helvetica Neue LT Pro Condensed weights work well in tables and infographics in which space can be limited.

Please exercise restraint when using different styles and weights of the font to preserve the integrity and consistency of Valley printed materials. To ensure the text is readable, the minimum size used for this font should be 8 point.

Adding drop shadows, highlights and dimension to type in headlines and body copy is not allowed. Simple, clean, readable type is the goal.

Helvetica Neue LT Pro Light

Aa Bb Cc Dd Ee Ff Gg Hh Ii Jj Kk Ll Mm
Nn Oo Pp Qq Rr Ss Tt Uu Vv Ww Xx Yy Zz
(.,:;!#\$%&@*) 0123456789

Helvetica Neue LT Pro Medium

**Aa Bb Cc Dd Ee Ff Gg Hh Ii Jj Kk Ll Mm
Nn Oo Pp Qq Rr Ss Tt Uu Vv Ww Xx Yy Zz
(.,:;!#\$%&@*) 0123456789**

Helvetica Neue LT Pro Bold

**Aa Bb Cc Dd Ee Ff Gg Hh Ii Jj Kk Ll Mm
Nn Oo Pp Qq Rr Ss Tt Uu Vv Ww Xx Yy Zz
(.,:;!#\$%&@*) 0123456789**

Helvetica Neue LT Pro Heavy

**Aa Bb Cc Dd Ee Ff Gg Hh Ii Jj Kk Ll Mm
Nn Oo Pp Qq Rr Ss Tt Uu Vv Ww Xx Yy Zz
(.,:;!#\$%&@*) 0123456789**

Helvetica Neue LT Pro Light Condensed

Aa Bb Cc Dd Ee Ff Gg Hh Ii Jj Kk Ll Mm
Nn Oo Pp Qq Rr Ss Tt Uu Vv Ww Xx Yy Zz
(.,:;!#\$%&@*) 0123456789

Helvetica Neue LT Pro Medium Condensed

**Aa Bb Cc Dd Ee Ff Gg Hh Ii Jj Kk Ll Mm
Nn Oo Pp Qq Rr Ss Tt Uu Vv Ww Xx Yy Zz
(.,:;!#\$%&@*) 0123456789**

Digital Valley Typeface

Because it is free and readily available, Roboto is the preferred font for online and web applications. It is a clean font, easy to read and suitable for subheads, body copy and tables.

Font Usage

Roboto is preferred for online applications only.

For the majority of uses, Roboto Light is preferred. Other weights and styles can be used when appropriate. For example, Roboto Bold would work well for subheads.

Please exercise restraint when using different styles and weights of the font to preserve the integrity and consistency of Valley online. To ensure the text is readable in web applications, the minimum size used for this font should be 12 point.

Roboto

Aa Bb Cc Dd Ee Ff Gg Hh Ii Jj Kk Ll Mm
Nn Oo Pp Qq Rr Ss Tt Uu Vv Ww Xx Yy Zz
(.,:;!#\$\$%&@*) 0123456789

Roboto Light

Aa Bb Cc Dd Ee Ff Gg Hh Ii Jj Kk Ll Mm
Nn Oo Pp Qq Rr Ss Tt Uu Vv Ww Xx Yy Zz
(.,:;!#\$\$%&@*) 0123456789

Roboto Medium

**Aa Bb Cc Dd Ee Ff Gg Hh Ii Jj Kk Ll Mm
Nn Oo Pp Qq Rr Ss Tt Uu Vv Ww Xx Yy Zz
(.,:;!#\$\$%&@*) 0123456789**

Roboto Bold

**Aa Bb Cc Dd Ee Ff Gg Hh Ii Jj Kk Ll Mm
Nn Oo Pp Qq Rr Ss Tt Uu Vv Ww Xx Yy Zz
(.,:;!#\$\$%&@*) 0123456789**

Roboto Condensed Light

Aa Bb Cc Dd Ee Ff Gg Hh Ii Jj Kk Ll Mm
Nn Oo Pp Qq Rr Ss Tt Uu Vv Ww Xx Yy Zz
(.,:;!#\$\$%&@*) 0123456789

Roboto Condensed Bold

**Aa Bb Cc Dd Ee Ff Gg Hh Ii Jj Kk Ll Mm
Nn Oo Pp Qq Rr Ss Tt Uu Vv Ww Xx Yy Zz
(.,:;!#\$\$%&@*) 0123456789**

Digital Valley Typeface

Oswald is a secondary typeface utilized for digital headlines, subheads and call to action statements. Because it is a very condensed font and can be difficult to read, it should not be used for body copy.

Font Usage

For the majority of uses, Oswald should be used in ALL CAPS.

Please exercise restraint when using Oswald. It is intended as a headline font only and should never be utilized for body copy.

Oswald Regular

**Aa Bb Cc Dd Ee Ff Gg Hh Ii Jj Kk Ll Mm
Nn Oo Pp Qq Rr Ss Tt Uu Vv Ww Xx Yy Zz
(.,:;!#S%&@*) 0123456789**

Oswald Extra Light

Aa Bb Cc Dd Ee Ff Gg Hh Ii Jj Kk Ll Mm
Nn Oo Pp Qq Rr Ss Tt Uu Vv Ww Xx Yy Zz
(.,:;!#S%&@*) 0123456789

Oswald Light

Aa Bb Cc Dd Ee Ff Gg Hh Ii Jj Kk Ll Mm
Nn Oo Pp Qq Rr Ss Tt Uu Vv Ww Xx Yy Zz
(.,:;!#S%&@*) 0123456789

Oswald Medium

**Aa Bb Cc Dd Ee Ff Gg Hh Ii Jj Kk Ll Mm
Nn Oo Pp Qq Rr Ss Tt Uu Vv Ww Xx Yy Zz
(.,:;!#S%&@*) 0123456789**

Oswald Demi Bold

**Aa Bb Cc Dd Ee Ff Gg Hh Ii Jj Kk Ll Mm
Nn Oo Pp Qq Rr Ss Tt Uu Vv Ww Xx Yy Zz
(.,:;!#S%&@*) 0123456789**

Oswald Bold

**Aa Bb Cc Dd Ee Ff Gg Hh Ii Jj Kk Ll Mm
Nn Oo Pp Qq Rr Ss Tt Uu Vv Ww Xx Yy Zz
(.,:;!#S%&@*) 0123456789**

Alternative Valley Typeface

Because it is readily available on a variety of platforms, Arial is the preferred font for business applications. It is also a preferred second font option for print if Helvetica is not available.

Font Usage

Arial Regular should be used in most business situations. To ensure the text is readable, the minimum size used for this font should be 12 point for web applications and 8 point for all other applications.

Arial

Aa Bb Cc Dd Ee Ff Gg Hh Ii Jj Kk Ll Mm
Nn Oo Pp Qq Rr Ss Tt Uu Vv Ww Xx Yy Zz
(.,:;!#\$%&@*) 0123456789

Arial Bold

**Aa Bb Cc Dd Ee Ff Gg Hh Ii Jj Kk Ll Mm
Nn Oo Pp Qq Rr Ss Tt Uu Vv Ww Xx Yy Zz
(.,:;!#\$%&@*) 0123456789**

Arial Narrow

Aa Bb Cc Dd Ee Ff Gg Hh Ii Jj Kk Ll Mm
Nn Oo Pp Qq Rr Ss Tt Uu Vv Ww Xx Yy Zz
(.,:;!#\$%&@*) 0123456789

Guidelines for all Product Names with “Valley”

When a product name includes the Valley name, the text should always be typeset in upper/lowercase unless otherwise indicated. The name Valley and product name should always be the same font, same font size and same font style. The font used for the product name can be created in any of the approved Valley fonts, weights or styles within each of the font families is acceptable.

Print Font Application

(Examples: brochures, posters, trade ads, direct mail, signage, etc.)

Forza is the approved Valley product name font.

NOTE: When Forza is utilized, any registered marks (such as ® or TM) need to be typeset in **Helvetica LT Pro**.

Example using Forza Black in single line application

Valley 365[®]

Example using Forza Black in stacked application

**Valley
365[®]**

Helvetica LT Pro is the substitute font for usage on product decals.

Example using Helvetica LT Pro Heavy on product decals

Aqua Trac Pro

Example using Helvetica LT Pro Black on decal
without Valley in product name



WEB FONT APPLICATION

(Examples: website, apps, email, landing pages etc.)

Roboto is the approved font for all web and online applications created.

Example using Roboto Regular

Valley 365[®]

Arial is the substitute font when Roboto is unavailable.

Example using substituted Arial Font

Valley 365[®]

Print Guidelines for All Product Name Applications

When a product name used in print, such as post cards, one-sheeters or brochures, the product name should be typeset in upper/lowercase unless otherwise indicated. This rule applies regardless of the font usage with the printed materials. The font used for the product name can be created in any of the approved fonts, weights or styles within the Valley brand standards.

If the recommended Forza font is utilized, any registered marks (such as ® or TM) need to be typeset in Helvetica LT Pro.

Examples using Forza Black

Valley 365[®]
Valley Scheduling[™]
Valley Precision Corner[®]
Valley ICON[®]

Product names can be created in any of the approved blue brand colors, in black or in white. NOTE: The entire product name needs to appear in the same color.

Approved colors



c100m10y0k10

Unapproved Usage Examples

~~Valley 365[®]~~

Do not set type in different fonts

~~Valley 365[®]~~

Do not set type in different font weights

~~Valley 365[®]~~

Do not set type in different font sizes

~~Valley 365[®]~~

Do not set type in different colors

~~Valley 365[®]~~

Do not set type in different font styles

~~VALLEY 365[®]~~

Do not set type in ALL CAPS

Print Guidelines for Co-brand Applications

When a product name with a co-brand is used in print, such as post cards, one-sheets or brochures, the product name should be typeset in upper/lowercase unless otherwise indicated. The descriptor line should always appear in all lower case. A distance of “x” should be maintained between the baseline of the product name and the baseline of the lowest descender of the descriptor line/co-brand logo (if applicable). This rule applies regardless of the font usage.

In the example below, the value “x” is the height of the “V” in Valley. The descriptor line, “powered by Prospera” is aligned left with the product name, “Insights”.

Example using Forza Black

height of V = x **Valley Insights**[®]
powered by prospera

x **Valley Insights**[®]
powered by prospera x

Web/Digital Guidelines for All Product Name Applications

When a product name used in web and online applications, the product name should be typeset in upper/lowercase unless otherwise indicated. This rule applies regardless of the font usage in Roboto or Arial.

Examples using Roboto Regular

Valley 365[®]
Valley Scheduling[™]
Valley Precision Corner[®]
Valley ICON[®]

Examples using Arial Regular

Valley 365[®]
Valley Scheduling[™]
Valley Precision Corner[®]
Valley ICON[®]

Web/Digital Guidelines for Co-brand Applications

When a product name with a co-brand is used in web or online applications, such as websites, apps, email, landing pages, the product name should be typeset in upper/lower case unless otherwise indicated. The descriptor line should always appear in all lower case. A distance of “x” should be maintained between the baseline of the product name and the baseline of the lowest descender of the descriptor line and co-brand. The value “x” is the height of the “Valley” from the top of the “l” to the bottom of the “y”.

In the example below, “powered by Prospera” is aligned left with the product name, “Insights”. The font used for web or online applications is Roboto. The Arial font can be substituted if needed for applications when the Roboto web/digital font is unavailable.

Example using Roboto Regular

height of Valley = x Valley Insights®
powered by prospera

Valley Insights®
powered by prospera x

Example using Arial Regular (The Arial font can be substituted if needed for web applications when Roboto is unavailable.)

height of Valley = x Valley Insights®
powered by prospera

Valley Insights®
powered by prospera x

Product Photography

Our product is our hero. Product photographs and video footage reinforce our brand positioning, establish a distinctive visual presence and create an emotional connection with our growers. If you have a special request for photography or video footage, please contact the Strategic Marketing Team.

Valley photography may be used with approval from the Strategic Marketing Team, but photos must include the following disclaimer:
Copyright Valmont Industries, Inc.



Correct



Incorrect

Avoid Discolored Machines

Avoid the use of photographs/video footage showing a machine that is discolored. Machines that look new are preferred. In some situations, such as for maintenance/upgrade promotions, the use of photographs showing slightly used machines is allowed.



Correct



Incorrect

Valley Overhang Sign

Photographs/video footage with the overhang sign on Valley machines must contain the most current Valley sign. (The word Valley with the graphic "V" trademark in a horizontal format.) The old Valley overhang sign can be used only if you are referring to Valley history or promoting maintenance on an old machine.

The Valley logo must be visible on the sign. The sign cannot be one solid color.

Brand Voice

Through the language we use, our voice lets the world experience our brand. Valley is confident that our solutions are the best. Our voice is anchored in that confidence, without being arrogant. Our brand voice is active, grower-focused and guided by the benefits of our solutions. It is conversational. It is humanizing. We put ourselves in our growers' shoes. We understand growers' concerns. We want to solve growers' problems. Our messages tell our growers how we can improve their businesses and lives. We focus on what makes us unique, what makes our solutions worth buying, and what differentiates us from other brands.

We use concise, active language written in first-person point of view. We tell stories about the benefits of our solutions, rather than simply listing specs and features. We communicate our confidence by focusing on what our solutions can do for our customers and why they need them.

Here are some examples:

Correct Voice:

Tree lines and buildings can get in the way of your irrigation operation, keeping valuable acres out of production. We understand this challenge, and that's why we offer the Bender product line for center pivots. Our Valley Benders can be easily, and inexpensively, added to your center pivot, putting extra acres into production and increasing your yields and profitability.

Our Benders can be installed on any span tower, and multiple Benders can be added to the same pivot for maximum benefit. We offer two Bender options to fit your needs: the Bender30™ and the Bender160™.

Incorrect Voice:

Valley has Bender options for center pivots that maximize irrigated areas for a minimal investment cost. Its Bender30 and Bender160 allow the outer portion of a pivot to continue moving while the inner portion is stopped by fences, trees or other obstacles.

- The Bender30 can bend up to 30 degrees in either direction while utilizing existing structural components and can be retrofit to an existing machine.
- The patent-pending Bender160 can bend up to 160 degrees in either direction and utilizes custom structural components
- Multiple bends per pivot are allowed.

Brand Description

If a publication requests information on Valley, please use the following text:

51 words:

Valmont® Irrigation is a leader in advancing agricultural productivity, allowing growers to produce more with less through engineered irrigation equipment and connected crop management applications. Our precision ag solutions use future-focused, leading-edge technology to leverage data and machine learning that allow growers to help feed a growing world population more efficiently and effectively.

75 words:

Valley®, Irrigation, a Valmont® company, has been the leader in advancing agricultural productivity, from the first center pivots in 1954 to the precision ag technology of today. Decades of thought leadership and technological innovation have helped growers increase food production and conservation of natural resources around the world. Valmont is a global leader in creating vital infrastructure and advancing agricultural productivity to improve life. Learn more about Valley Irrigation at valleyirrigation.com and Valmont at valmont.com.

Authorized Providers

We work with many valuable providers for parts and services. When referencing them, please use the terminology “Authorized Providers.”

Authorized Providers Include:

- Nelson®
- Senninger® Irrigation Inc.
- Diversified Financial Services, LLC

Correct: Authorized Providers

Incorrect: Preferred Providers

Valmont Irrigation Logo Usage

The Valmont Irrigation logo should be used on invoices, legal items and on the back cover of brochures.

Download the approved logos from valleyirrigation.com/brand.

Spacing & Positioning of the Valmont Irrigation Logo

The size and spacing relationships, or "lock ups," between the trademark and logotype are of such importance to the overall image of Valmont that any changes or modifications are unacceptable.

Maintaining the visual balance is simple, given the following guidelines. The unit "x," as the examples note, is equal to the height of the "l" in "valmont." All other proportions are based on this unit. There must be allowance for generous amounts of background space around the signature. The signature clear zone is depicted below. No type, photographs or other design elements can be placed within this zone. This zone measures 2X horizontally from the top of the ascender and from the lowest baseline. It measures 1X left and right of the signature. Whenever possible, this much space should be used. There will be instances when space is at a premium and the preferred clear zone must be lessened. In these cases, the "minimum signature clear zone" must be used.

The relationships diagrammed here are the only acceptable signature lock ups.

Valmont Irrigation logo



All black



All white



02

**TRADEMARKS
& COPYRIGHTS**

VALLEY. IRRIGATION BRAND GUIDELINES

Registered & Unregistered Trademarks

Trademark registration provides enhanced legal protection and can help prevent other companies from using proprietary products, services, goods, logos, symbols or designs.

Two different legal markings are used with trademarks:

Registered Trademark ®

A ® symbol indicates that a mark has been federally registered with the U.S. Patent and Trademark Office. It is a symbol of registration and only should be used with federally registered marks.

Unregistered Trademark ™

A ™ symbol indicates notice of pending trademark registration and/or a claim of rights to the mark. Once a name is registered with the Patent and Trademark Office, the ™ or identifier is replaced with a ®.

To ensure proper use and protection of the Valley marks, please follow the recommended applications outlined in this section.



The Valley Logo

- The Valley logo is registered to Valmont Industries, Inc. Anyone using the logo must be authorized to do so, and must always abide by the standards detailed in this document.
- Always ensure that the registration symbol is positioned in subscript (bottom right of the Valley "V"), as shown in the logo above.
- The registration symbol is set in the artwork and must accompany the logo. Do not remove the registration mark without prior approval from the Strategic Marketing Team. (An example in which it may be appropriate to remove the mark would be on apparel where the ® is illegible when embroidered.)

Trademarks & Registration Marks

Many Valley terms and product names are registered, and many others require a trademark symbol. Please follow the guidelines below to ensure proper usage:

- Use the ™ or ® symbol in the first mention of any name listed below in the headline and the body copy on any advertising or promotional material, regardless of the medium. Examples include the first mention on each page of a brochure or the first time it appears on each individual web page.
- While omission of the ™ or ® symbol does not invalidate a trademark owner's rights, it is one of the primary ways to ensure protection because it alerts the public to the ownership of a legal mark.
- A list of Valley trademarks and registered marks can be found on this page. As properties are updated periodically, please refer to the most recent Brand Guidelines PDF each time you develop communications materials to ensure proper use.

Placement of the Registration Mark

For those marks that are federally registered, we follow this strategy for placement of the registration mark:

Registered Product Names

- Place the ® to the right of the mark in superscript
- This strategy should be followed for both product names in logo form and in text

Sample logo treatment



Sample text treatment

Valley ICON®

Registered Brand Marks and Taglines

- Place the ® to the right of the mark in subscript
- This strategy should be followed for both brand marks/taglines in logo form and in text

Sample logo treatment



Sample text treatment

Valley®, *The Leader in Precision Irrigation.*

Trademarks & Registration Marks

The following names currently carry a ® mark:

Valley®

(Registered in: Australia, Argentina, South Africa, Brazil, China, Canada, Chile, Cuba, New Zealand, Paraguay, Peru, Spain, United States, United Arab Emirates, Uruguay, Venezuela, European Union, Saudi Arabia)

Valmont®

(Registered In: AIPO (African Union), Argentina, Australia, Brazil, Canada, Chile, China, Colombia, Cuba, El Salvador, European Union, India, Indonesia, Kuwait, Malaysia, Morocco, New Zealand, Nicaragua, Norway, Paraguay, Philippines, Russian Federation, Saudi Arabia, Singapore, South Korea, Spain, Switzerland, Turkey, United States, Venezuela, Vietnam)

Valley 8000 Series®

(Registered in: United States)

Valley 365®

(Registered in: Argentina, Brazil, Canada, Chile, European Union, Saudi Arabia, South Africa, United Arab Emirates, United Kingdom, United States)

Valley Blueprint®

(Registered in: United States)

Valley ICON®

(Registered in: Argentina, Brazil, European Union, New Zealand, Russia, South Africa, Ukraine, United Kingdom United States)

Valley Insights®

(Registered in: Valley Insights also registered in Australia, Brazil, European Union, New Zealand, Russia, United Kingdom United States)

Valley Irrigation Exchange®

(Registered in: United States)

Valley Irrigation Run Time®

(Registered in: United States)

Valley PivotPoint®

(In reference to our newsletter, registered in: United States)

Valley Precision Corner®

(Registered in: Argentina, Canada, China, United States)

AgSense®

(Registered in: New Zealand, United States)

CommanderVP®

(Registered in: United States)

Crop Link®

(Registered in: United States)

Field Commander®

(Registered in: Australia, Chile, European Union, New Zealand, Russia, Saudi Arabia, United Arab Emirates, United Kingdom, United States)

PolySpan®

(Registered in: United States)

Water Sentinel®

(Registered in: United States)

Valley X-Tec®

(Registered in: United States)

The following Valley products currently carry the ™ designation:

BaseStation2™

BaseStation3™

Bender30™

Bender160™

CableGuard™

Cruise Control™

DropSpan™

DualDrive™

DualSpan™

E-Z Tow™ (2-Wheel E-Z Tow™)

FastPass™

Rainger™

Spinner™

Valley Revolution™ Airless Tire

Valley Scheduling™

Valmont Solar™ Solutions

VFlex™

The following taglines currently carry a ® mark:

The Leader in Precision Irrigation®

(Registered in: United States)

Smart Panels Made Easy®

(Registered in: United States)

Usage of Brand & Product Names in Text

When you use the Valley brand name in text, do not repeat the style elements (e.g., font and color) of the logo. This means the Valley name should appear in the same font, type size and color as the rest of the text.

Brand & Product Name Usage

Never use a brand name as a possessive:

Correct Usage: Valley technology leads the market.

Incorrect Usage: Valley's technology leads the market.

Correct Usage: The products from Valley Irrigation are the best in the industry.

Incorrect Usage: Valley Irrigation's products are the best in the industry.

Never use the brand name in the plural form:

Correct Usage: How many Valley center pivots do you operate on your land?

Incorrect Usage: How many Valleys do you operate on your land?

Never use the word "systems" when referring to Valley equipment:

Correct Usage: Valley center pivot equipment

Incorrect Usage: Valley center pivot systems

Never use the word "mechanized irrigation" when referring to center pivot and linear irrigation:

Correct Usage: Valley center pivot and linear irrigation

Incorrect Usage: Valley mechanized irrigation

03

IDENTIFICATION

VALLEY. IRRIGATION BRAND GUIDELINES

Letterhead Guidelines

These guidelines are designed to reinforce a consistent brand image. Letterhead consistency will help build brand equity throughout the company.

1. Valley A Valmont Company Logo
width = 2.625"
colors: Pantone Process Blue
2. Address Block:
Helvetica Neue LT 45 Light
type size 8.5 pt / leading 11 pt
kerning -10
color: Black
3. Line Height: .75"
Weight: 1 pt.
Color: Pantone Process Blue

Recommended Paper:
Classic Crest Solar White - 28# Text

Download digital files from
valleyirrigation.com/brand.

The digital version of the
letterhead for emailing letters
can be found using the link above.

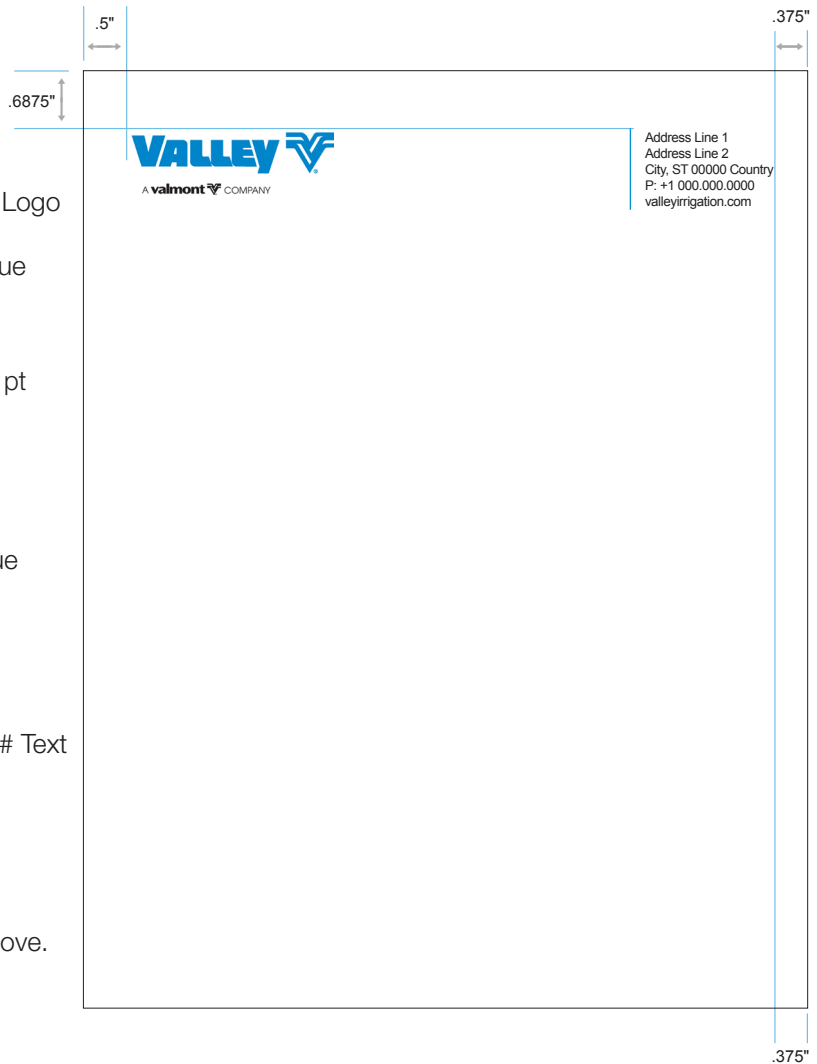

Ordering:

To order business cards, letterhead or envelopes, visit valmont.com/brand, click on the Stationery tab and follow the instructions. Please note: The instructions are different depending on whether the order is shipped inside or outside the United States. Those outside the U.S. can utilize template files on valmont.com/brand for use by a local printer in your area. The templates have organized fields for you to plug in your information to create print-ready proofs.

Envelope Guidelines

Envelopes should use the same style specifications to ensure consistency in design.



1. Valley A Valmont Company Logo
width = 1.5"
colors: Pantone Process Blue
2. Address Block:
Helvetica Neue LT 45 Light
type size 8 pt / leading 10 pt
colors: Black

Additional Envelope Artwork Sizes Available

- #9 - 3 7/8" x 8 7/8"
- #11 - 4 1/2" x 10 3/8"
- 9 1/2" x 12 1/2"
- 9" x 12"

Recommended Paper for #10 envelopes:
White Wove - 28# Text

Download digital files from
valleyirrigation.com/brand.

Ordering:

To order business cards, letterhead or envelopes, visit valmont.com/brand, click on the Stationery tab and follow the instructions. Please note: The instructions are different depending on whether the order is shipped inside or outside the United States. Those outside the U.S. can utilize template files on valmont.com/brand for use by a local printer in your area. The templates have organized fields for you to plug in your information to create print-ready proofs.

Business Card Guidelines

Our business cards are often the first and longest-lasting impression of our corporate identity. The cards are set up for printing and should not be altered.

The order of the contact information must follow the example below: address, office phone number and/or mobile number (optional), fax number (optional), then company URL. Name, title and email address should appear on the left side.

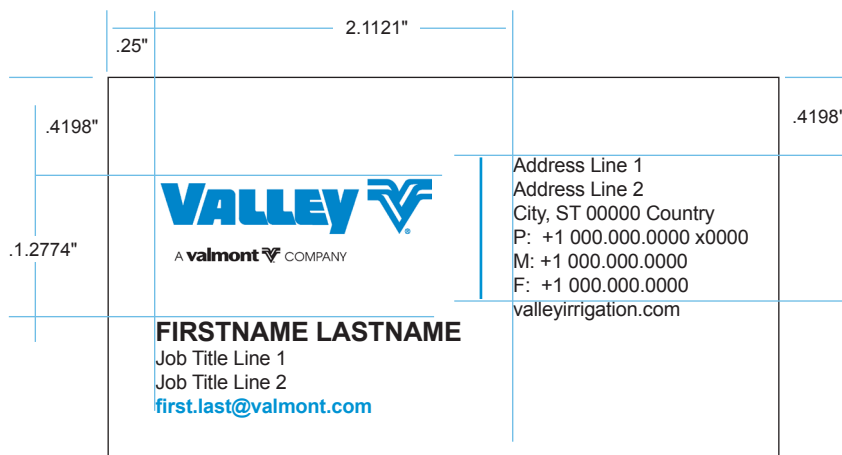

Note: Those individuals working remotely should use the most appropriate address for receipt of mail and business correspondence. This could include most accessible office location, home address or a personal PO Box depending on your situation.

1. Valley A Valmont Company Logo
width = 1.5"
colors: Pantone Process Blue
2. Name: ALL CAPS
Helvetica Neue LT 75 Bold
type size 10 pt / leading 9 pt
color: Black
3. Title: Helvetica Neue LT 45 Light
type size 7.5 pt / leading 9 pt
color: Black
4. Email: Helvetica Neue LT 55 Roman
type size 7.5 pt / leading 9 pt
colors: Pantone Process Blue
5. Address Block: Helvetica Neue LT 55 Light
type size 7.5 pt / leading 9 pt
color: Black
6. Line Height: .75"
Weight: 1 pt.
Color: Pantone Process Blue

Paper: Classic Crest
Color: Solar White
Weight: Classic Crest -110# Cover
Size: 3.5" x 2"

Download digital files from
valleyirrigation.com/brand.

Ordering:

To order business cards, letterhead or envelopes, visit valmont.com/brand, click on the Stationery tab and follow the instructions. Please note: The instructions are different depending on whether the order is shipped inside or outside the United States. Those outside the U.S. can utilize template files on valmont.com/brand for use by a local printer in your area. The templates have organized fields for you to plug in your information to create print-ready proofs.

Dealer Business Cards

Branding requires consistency and uniformity at all levels. It remains critical and important to Valley.

The Valley dealer business cards are designed to include placement for individual dealer logos, if applicable. The cards are set up for printing and, ideally, should not be altered. Please contact the Strategic Marketing Team prior to making any modifications or layout adjustments.

Paper: Classic Crest
Weight/Color: 24# Whitestone
Size: 3.5" x 2"

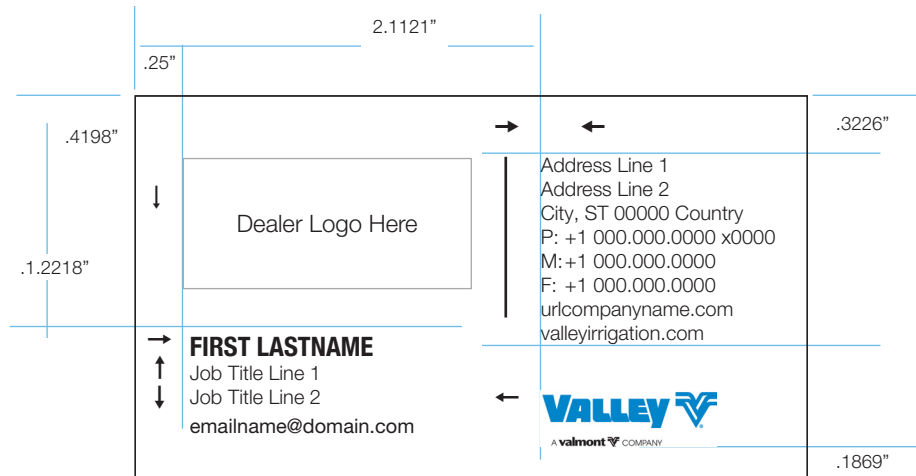

To order new dealer business cards, go to: <https://order.taylorcommunications.com/>

1. Dealer Logo: max width 1.5"
color: determined by logo
2. Valley Logo: width 1:05"
color: Pantone Process Blue
3. Name: ALL CAPS
Helvetica Neue LT 75 Bold
type size 10 pt / leading 9 pt
color: Black
4. Title: Helvetica Neue LT 45 Light
type size 7.5 pt / leading 9 pt
color: Black
5. Email: Helvetica Neue LT 55 Roman
type size 7.5 pt / leading 9 pt
color: Black
6. Address Block:
Helvetica Neue LT 55 Roman
type size 7.5 pt / leading 9 pt
color: Black
7. Line: Height should equal
height of address block
weight: 1 pt.
color: Black 40%

Email Signature Guidelines

With the number of emails we all send every day, the email signature has replaced the business card as our primary form of identity and association with Valley Irrigation.

In order to convey a single brand voice, it is important that we all deliver the same consistent message across our Valley email signatures. Please use the following guidelines when setting up your branded email signature block for your desktop and company-issued mobile device.

Please use the below template, copy and paste it into your signature block and replace with your specific information to build your own signature. Two options are available:

Option #1: Corporate and Segment Employees

First/Last Name | Job Title

Company Name | Address 1 | Address 2 (optional) | City, ST 00000 Country

Phone +1 000.000.0000, ext. 0000 | Mobile (optional) | Fax (optional)

Email Address | **Valmont or Segment URL** (Use your Country URL here.)

Option #2: Sub-Brand/Acquired Brand Employees

First/Last Name | Job Title

Sub-Brand Name – a Valmont company | Address 1 | Address 2 (optional) | City, ST 00000 Country

Phone +1 000.000.0000, ext. 0000 | Mobile (optional) | Fax (optional)

Email Address | **Valmont or Segment URL** (Use your Country URL here.)

Please note: When copying and pasting into Outlook, you may have to change the pasted text from the default font (Calibri) to Arial. To do this, highlight the whole signature block and choose Arial from the font menu drop down.

If you encounter issues with copying and pasting the templates above, you can input your own information using this simple guide:

| | | |
|-------------------------|-----------------------------------|---------------------|
| Your Name/Company Name: | Font: Arial Bold 10 pt. | Color: Black |
| All other text: | Font: Arial Regular 10 pt. | Color: Black |
| Email and Web Links: | Font: Arial Bold 10 pt. | Color: RGB 0/95/131 |

If your mobile device does not allow you to build this signature or changes the format when pasting, the following is an acceptable substitute:

First/Last Name

Job Title

Company Name

Phone (optional) | Mobile (optional)

(Must include at least one phone number)

Please Remember: All font sizes, font weights and text colors must remain as provided (with the exception of the mobile device). Images (including logos), fun/inspirational quotes, third-party accreditation or accolades, false job titles and backgrounds in your email signatures are not acceptable.

Unacceptable Usage Examples:

Follow our new  page

John Doe | Position Title
Company Name
Address Line
Mobile +1 000.000.0000
john.doe@valmont.com

John Doe | Position Title
Company Name
Address Line
Phone +1 000.000.0000
john.doe@valmont.com

Safety: Knowing what can hurt you, learning the things that can keep them from hurting you and doing those things.



Voicemail Guidelines

Your voicemail message is the chance to relate and identify with the Valmont brand voice. When we all deliver the same consistent message our voicemail can be a powerful branding tool.

When you record your voicemail message, remember to:

- Use a friendly/helpful tone
- Speak in an appropriate speed, not too slow or fast
- Use a language that is native to you and your customers
- Listen to your message after you've recorded your voicemail

Please select an approved voicemail script from the following:

Basic: This script is broad and will apply to any caller in most situations.

“Hello, this is (INSERT FIRST AND LAST NAME) at Valmont. I’m sorry I missed your call. Please leave your name, number and a short message after the tone, and I will return your call as soon as possible. Thank you.”

Other Contact Options: If you would like to leave your caller additional contact options (contact an assistant, email instead of voicemail, call your mobile number, etc.), this script will provide that option for your caller.

“Hello, this is (INSERT FIRST AND LAST NAME) at Valmont. I’m sorry I missed your call. Please leave your name, number and a short message after the tone, and I will return your call as soon as possible. Or, if you’d prefer, you can contact me by (INSERT ONE ALTERNATE CONTACT METHOD). Thank you.”

Out of Office: If you will be out of the office for an extended period, please use the message below during your absence and to refer the caller to someone else in your area.

“Hello, this is (INSERT FIRST AND LAST NAME) at Valmont. I’m sorry I missed your call. I will be away from the office until (INSERT DAY, DATE). Please leave your name, number and a short message after the tone. I will return your call when I am back in the office. Or, you may contact (NAME) at (PHONE NUMBER OR EMAIL ADDRESS) and (HE/SHE) will be glad to assist you. Thank you.”

For more examples of approved voicemail scripts and additional tips to improve your recording, please visit valmont.com/brand for the comprehensive voicemail guidelines.

04

TEMPLATES

VALLEY. IRRIGATION BRAND GUIDELINES

PowerPoint Template

In order to capitalize on the Valley brand name, a standardized, clean and consistent Valley PowerPoint template has been created for your presentations. Using the standardized template provides the strongest professional representation of the Valley brand. This PowerPoint design is mandatory for Valmont employees. Valley dealers are not required to use this design.

The key elements within the PowerPoint template – logo, logo size, logo placement, font, accent colors, headers, footers – cannot be altered. Type size can be adjusted as appropriate to fit the amount of information presented on each slide.

The Valley Irrigation PowerPoint template can be downloaded from valleyirrigation.com/brand.

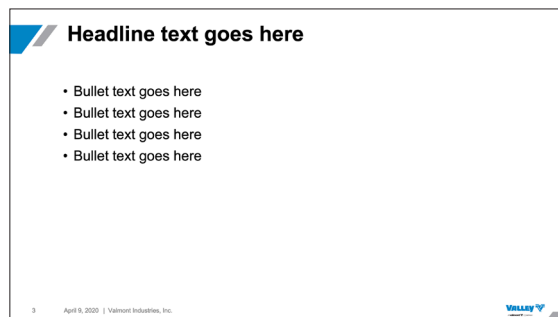
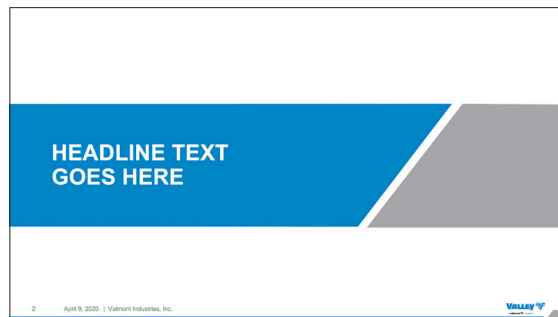

Important Notice:

Please use the Valmont Irrigation PowerPoint template when including content regarding Valley Irrigation and Valmont Tubing products.

Internal Communications

In an effort to simplify and unify our communication as One Valmont, all internal communication must use Valmont-branded versions of the templates featuring only the Valmont logo.

It's important that the communications are approved by management before distribution.

- The New Employee Announcement template should be used when announcing a new hire.
 - Valmont has two ways to announce new employees, depending on the role within the company. Please consult with your HR Business Partner prior to using the New Employee Announcement.
- The Employee Retirement Announcement template should be used when announcing a retirement.
- The Memo template should be used for all other internal communications.

These templates are available for download at valmont.com/brand.

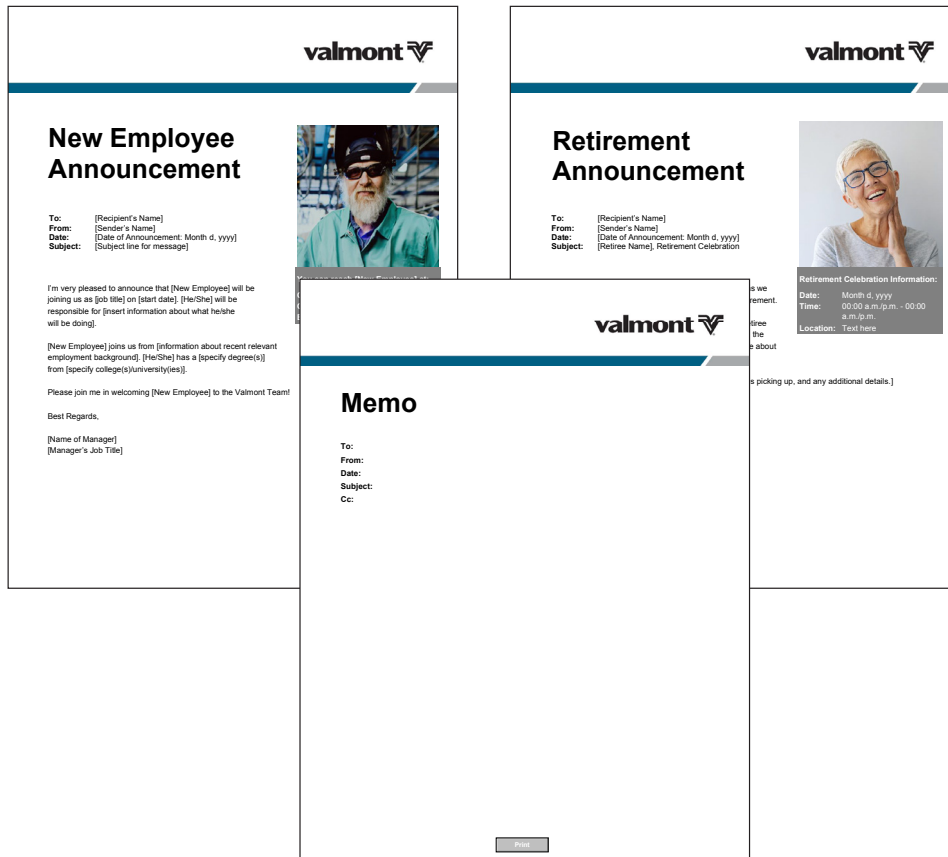

Bulletins

Bulletin templates should be used by all Valmont employees. Valley dealers are not required to use these templates.

In order to maintain the Valley brand, artwork should not be moved on these files.

The following templates are available:

- Aftermarket
- Marketing
- Sales
- Service
- Warranty
- Product Application
- Product Management

These templates can be downloaded from valleyirrigation.com/brand.

Sales

VB

Date: _____

To: _____

From: _____

Subject: _____

Your copy will start here...

Warranty

SB

Date: _____

To: _____

From: _____

Subject: _____

Your copy will start here...

Page 1 of 1

05

**SIGNAGE
& FLAGS**

VALLEY. IRRIGATION BRAND GUIDELINES

Valley Outdoor Signage

The first impression is often made through your dealership signage. To create a consistent image of the Valley brand, it is vital to follow common principles of identification.

Signage solutions are available for all building configurations based on size, distance and height.

Double-Face Flag Single-Pole Mount

The unique pole design will let the Valley name stand out along your property's right of way. For high visibility at night, all illuminated signs use LED lighting and are built and assembled to UL Code.

Please reference the Valley Outdoor Signage Options order form on valleyirrigation.com/brand.

If you are ordering outside the U.S., please work with a local vendor to have the signage created. Contact the Strategic Marketing Team if you have questions.

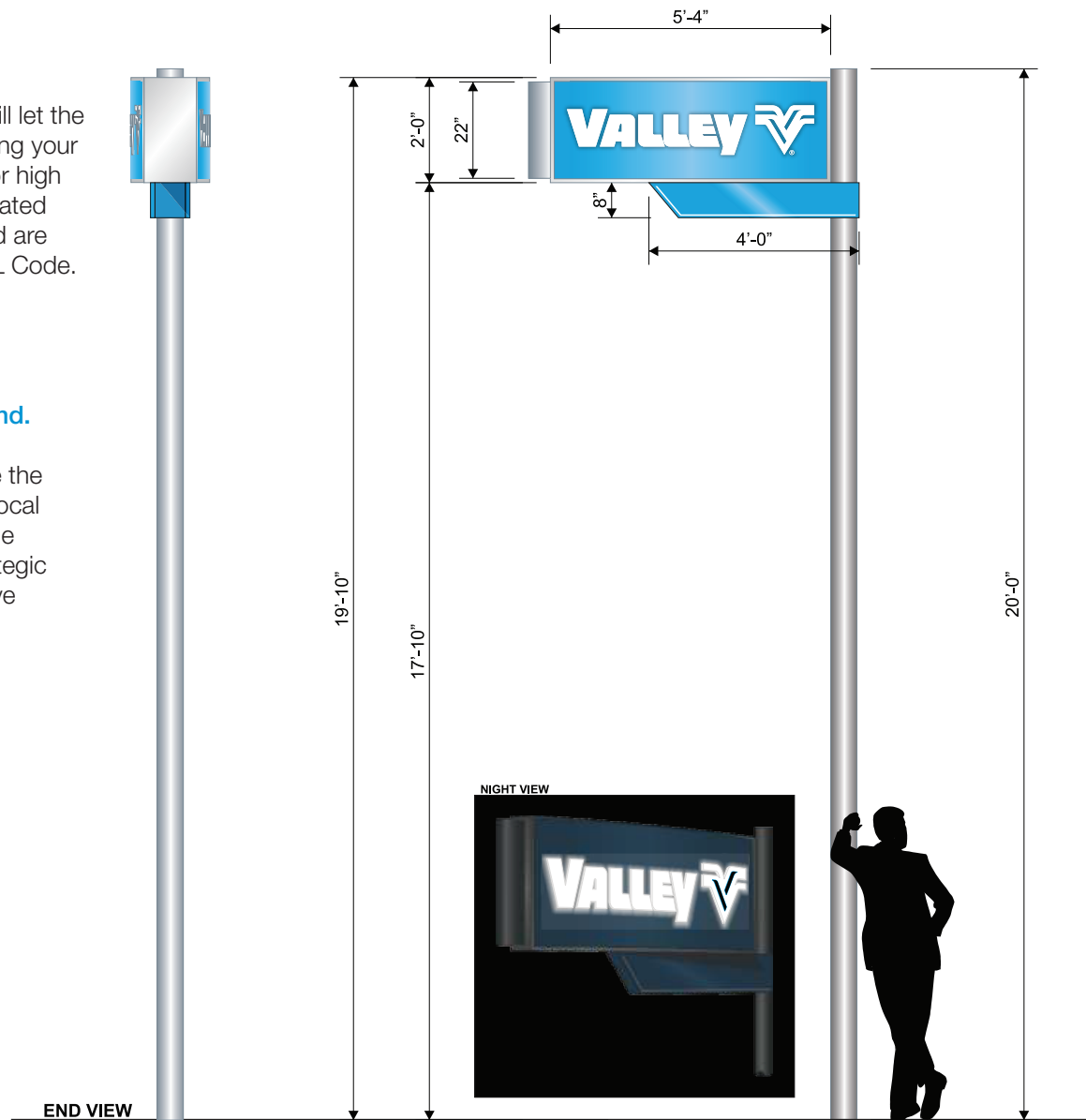

Valley Outdoor Signage

Double-Face Dual-Pole Mount

Whether you select single-pole or double-pole signs, both are designed to exceed wind-tolerance specifications.

The unique pole design will let the Valley name stand out along your property's right of way. For high visibility at night, all illuminated signs use LED lighting and is built and assembled to UL Code.

Please reference the Valley Outdoor Signage Options order form on valleyirrigation.com/brand.

If you are ordering outside the U.S., please work with a local vendor to have the signage created. Contact the Strategic Marketing Team if you have questions.

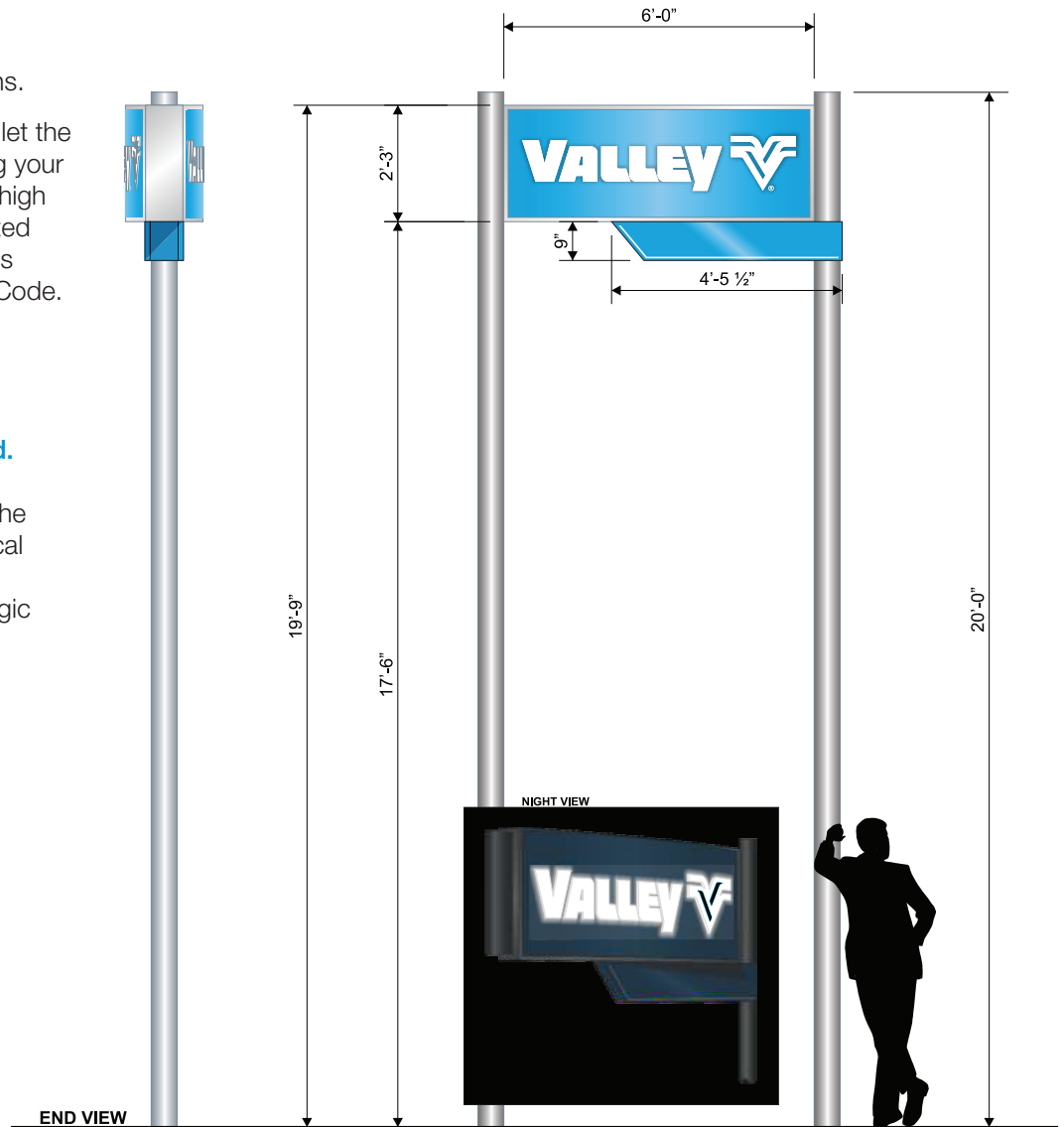

Valley Outdoor Signage

Dual 9' Pole

This 9' double-pole design allows for greater visibility, and LED lighting helps attract attention to your location, day or night, and is built and assembled to UL Code. The taller pole and enlarged sign is designed to exceed wind-tolerance specifications.

Please reference the Valley Outdoor Signage Options order form on valleyirrigation.com/brand.

If you are ordering outside the U.S., please work with a local vendor to have the signage created. Contact the Strategic Marketing Team if you have questions.



Valley Outdoor Signage

Dual ID 9' Pole

This 9' double-pole design allows for greater visibility, and LED lighting helps attract attention to your location, day or night, and is built and assembled to UL Code. The taller pole and enlarged sign is designed to exceed wind-tolerance specifications. The additional real estate below the Valley sign allows for dealership identification.

Please reference the Valley Outdoor Signage Options order form on valleyirrigation.com/brand.

If you are ordering outside the U.S., please work with a local vendor to have the signage created. Contact the Strategic Marketing Team if you have questions.

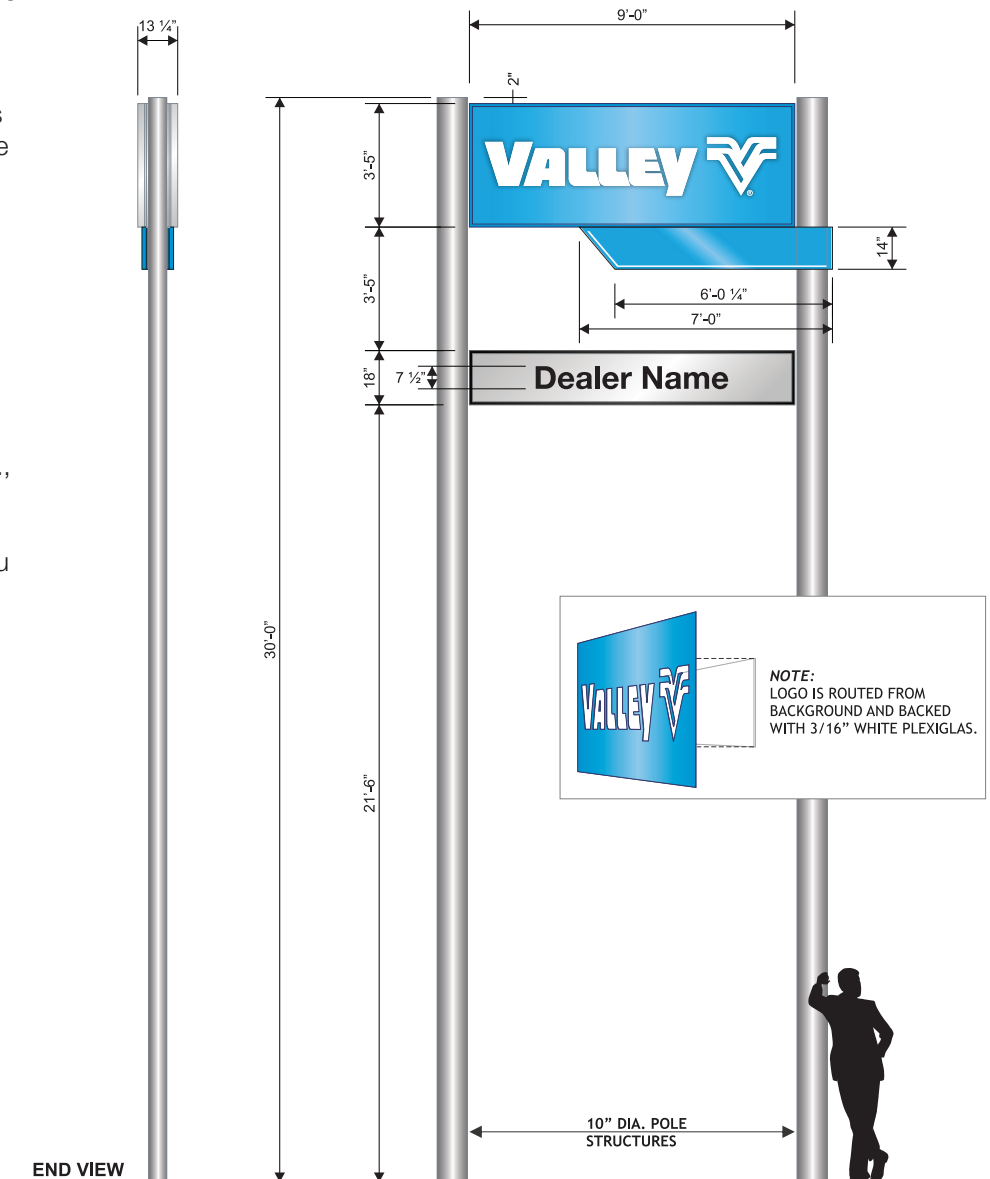

Valley Outdoor Signage

Dual 11' Pole

For ultimate visibility, this 11' double-pole design ensures identification from longer distances. LED lighting illuminates the location, day or night, and is built and assembled to UL Code. The taller pole and enlarged sign is designed to exceed wind-tolerance specifications.

Please reference the Valley Outdoor Signage Options order form on valleyirrigation.com/brand.

If you are ordering outside the U.S., please work with a local vendor to have the signage created. Contact the Strategic Marketing Team if you have questions.

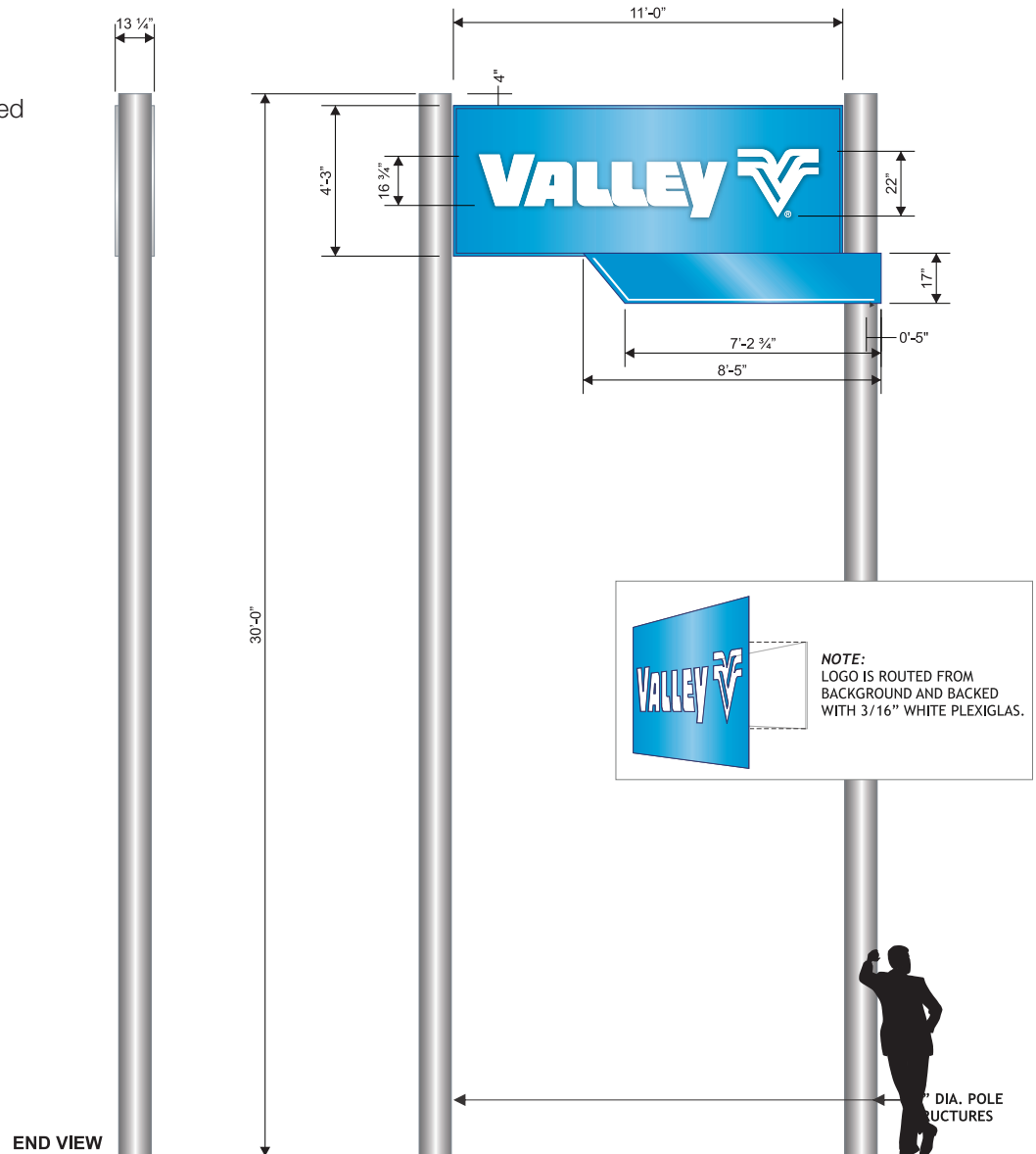

Valley Outdoor Signage

Dual ID 11' Pole

For ultimate visibility, this 11' double-pole design ensures identification from longer distances. LED lighting illuminates the location, day or night, and is built and assembled to UL Code. The taller pole and enlarged sign is designed to exceed wind-tolerance specifications. The additional real estate below the Valley sign allows for dealership identification.

Please reference the Valley Outdoor Signage Options order form on valleyirrigation.com/brand.

If you are ordering outside the U.S., please work with a local vendor to have the signage created. Contact the Strategic Marketing Team if you have questions.

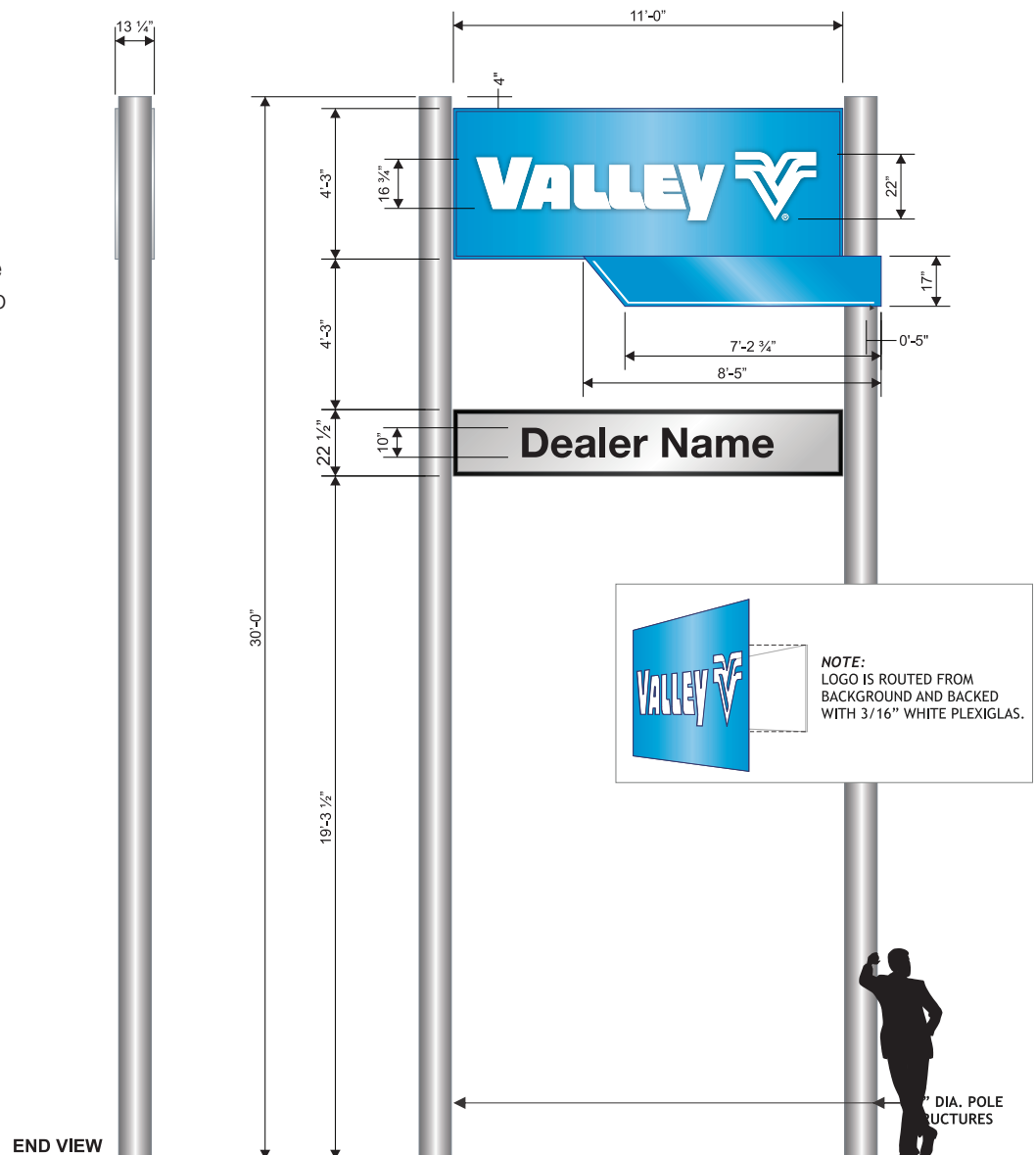

Valley Outdoor Signage

Double-Face Flag Dual-Pole Mount with Dealership Name

The additional real estate below the Valley sign provides two options for unique dealership identification.

Both identification sign options are shown in the diagram.

If you are ordering outside the U.S., please work with a local vendor to have the signage created. Contact the Strategic Marketing Team if you have questions.

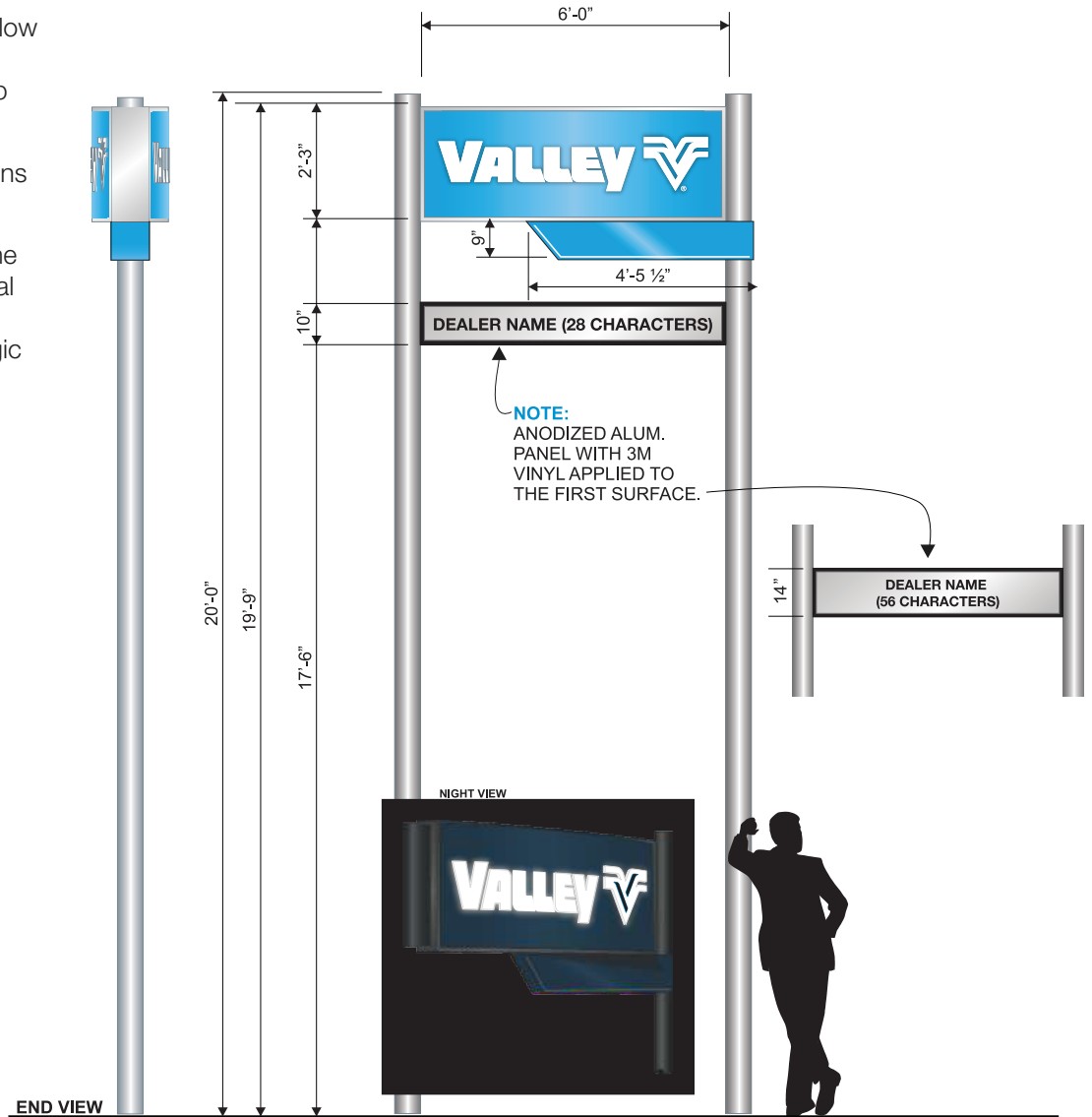

Valley Outdoor Signage

Single-Face Wall Mount

For maximum effect, wall signs need to be placed in locations that are visible from the road and near high-traffic areas (pedestrian or auto) on your property.

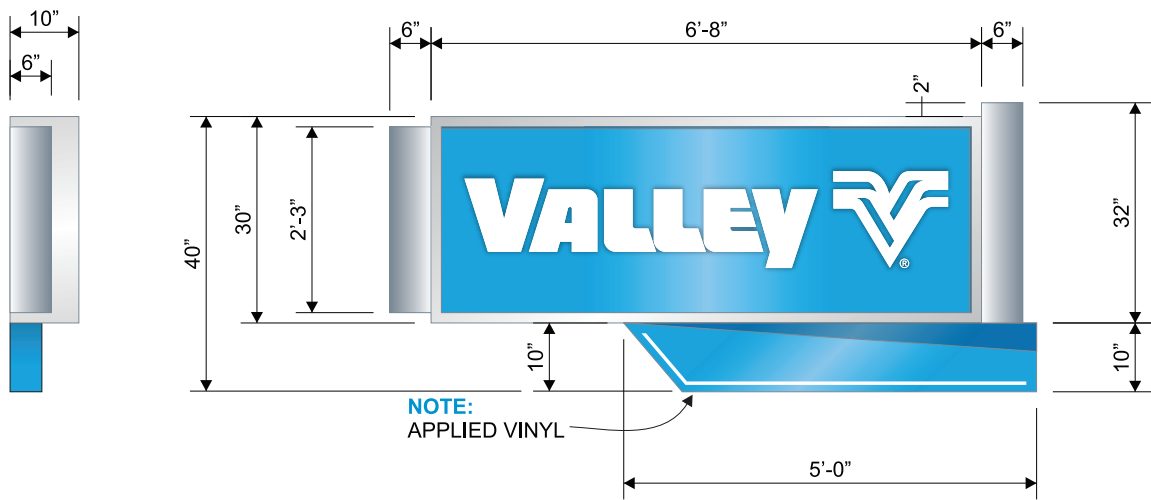

NIGHT VIEW



Valley Outdoor Signage

Double-Face Projection Mount

A flush-mounted flag sign allows your wall sign to be visible to traffic approaching the location from either direction.

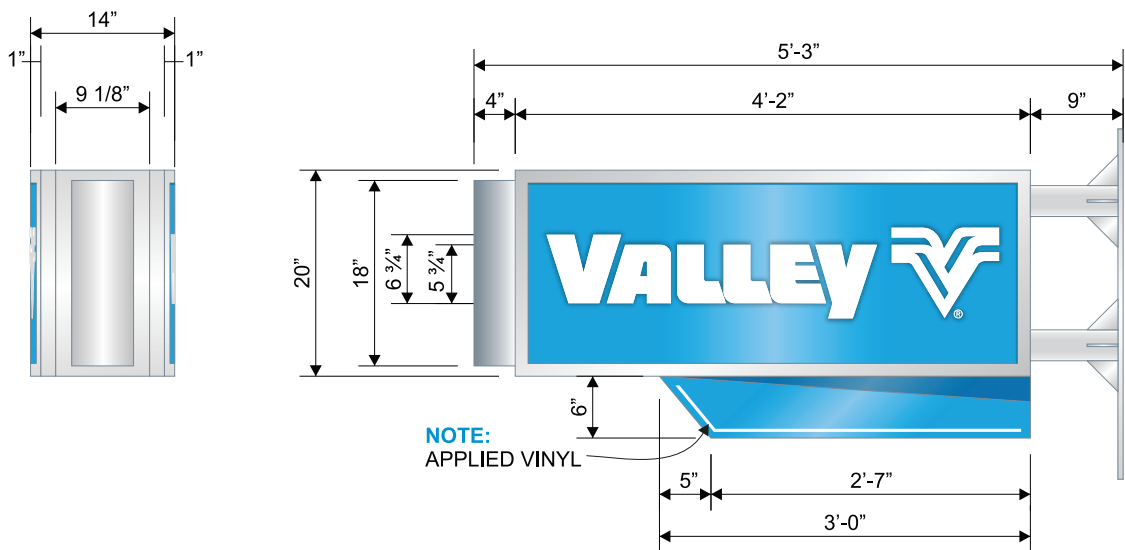

NIGHT VIEW



Valley Outdoor Signage

Double-Face Corner Projection Mount

A corner-mounted flag sign allows your wall sign to be visible to traffic approaching the location from either direction.

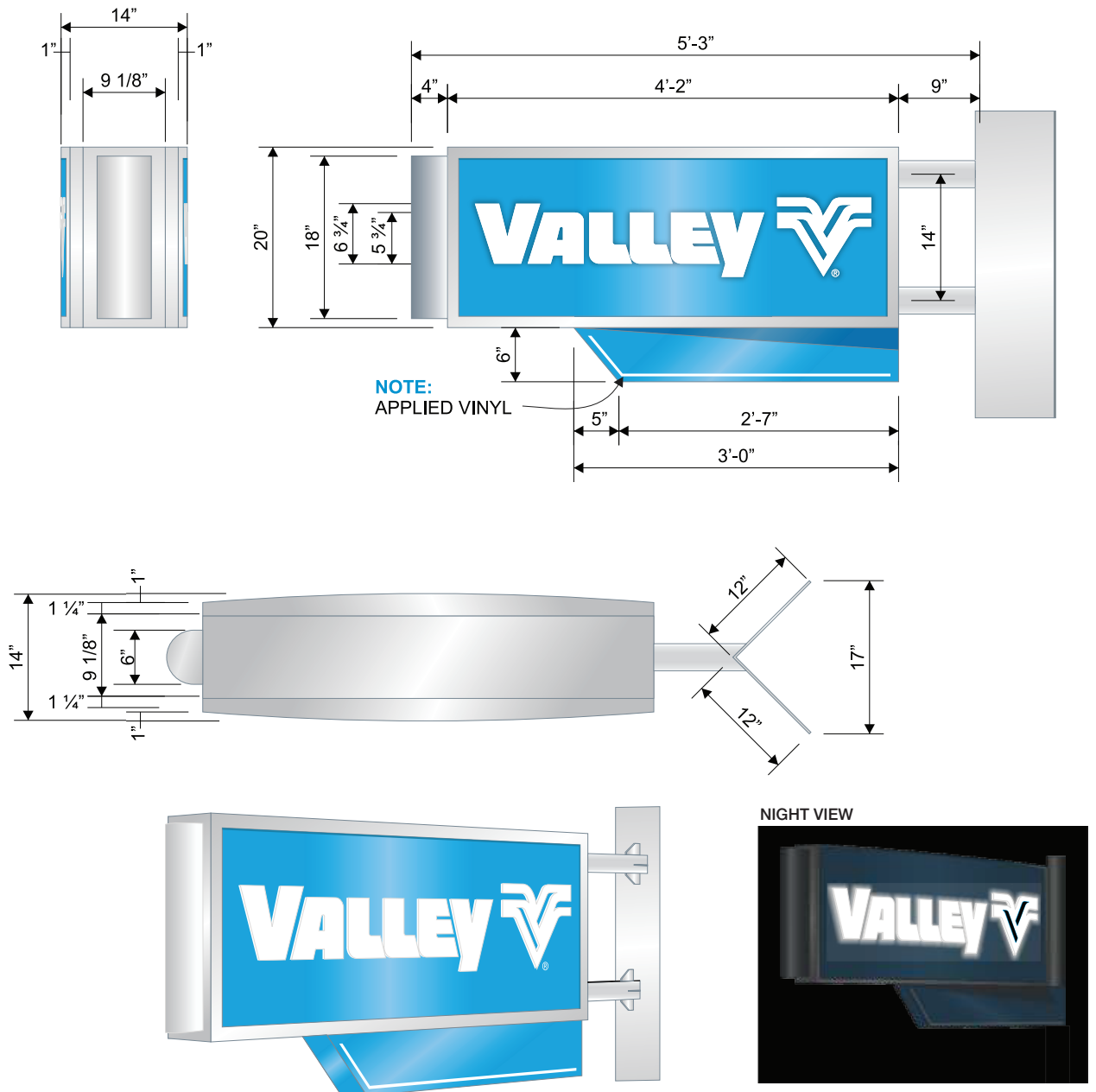

Valley Outdoor Signage

Double-Face Monument

Make a big impression, strengthen your corporate identity and dramatically increase your business's exposure with a monument sign.

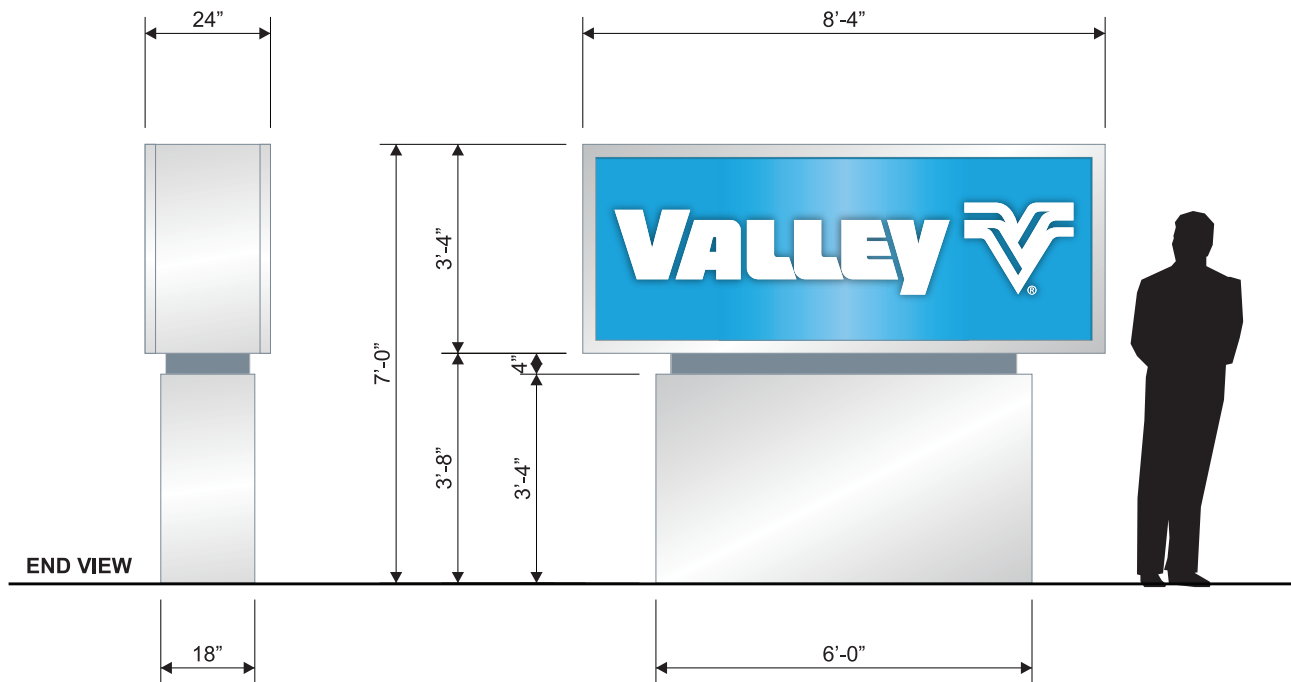

Valley Outdoor Signage

Double-Face Monument with Dealer Name

Make a big impression, strengthen your corporate identity and dramatically increase your business's exposure with a monument sign. The additional real estate below the Valley sign can be customized for unique dealership identification.

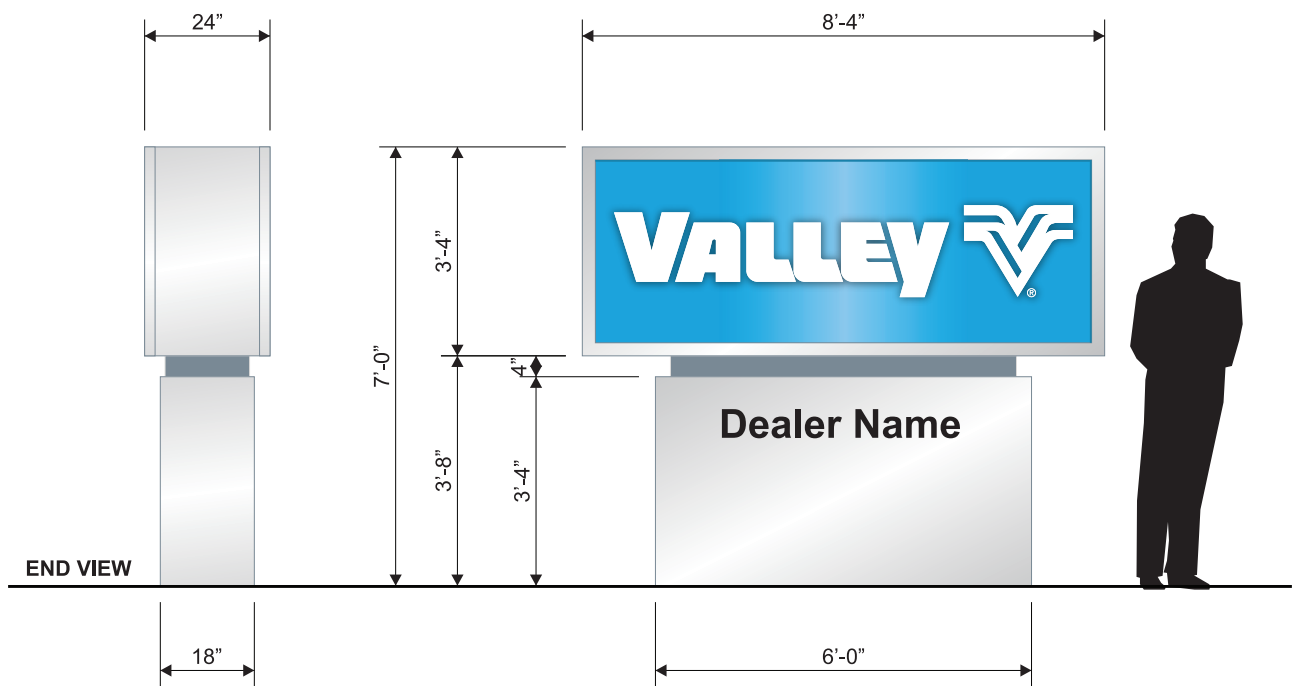

Awnings

Building awnings add a cohesive look, enhancing the Valley brand at your local level. Awning solutions are available for all building configurations.

Valley Logo-Only Awnings

A single, horizontal Valley logo is centered within the overall length of the awning structure. Repeating the Valley logo on each awning section is not recommended.

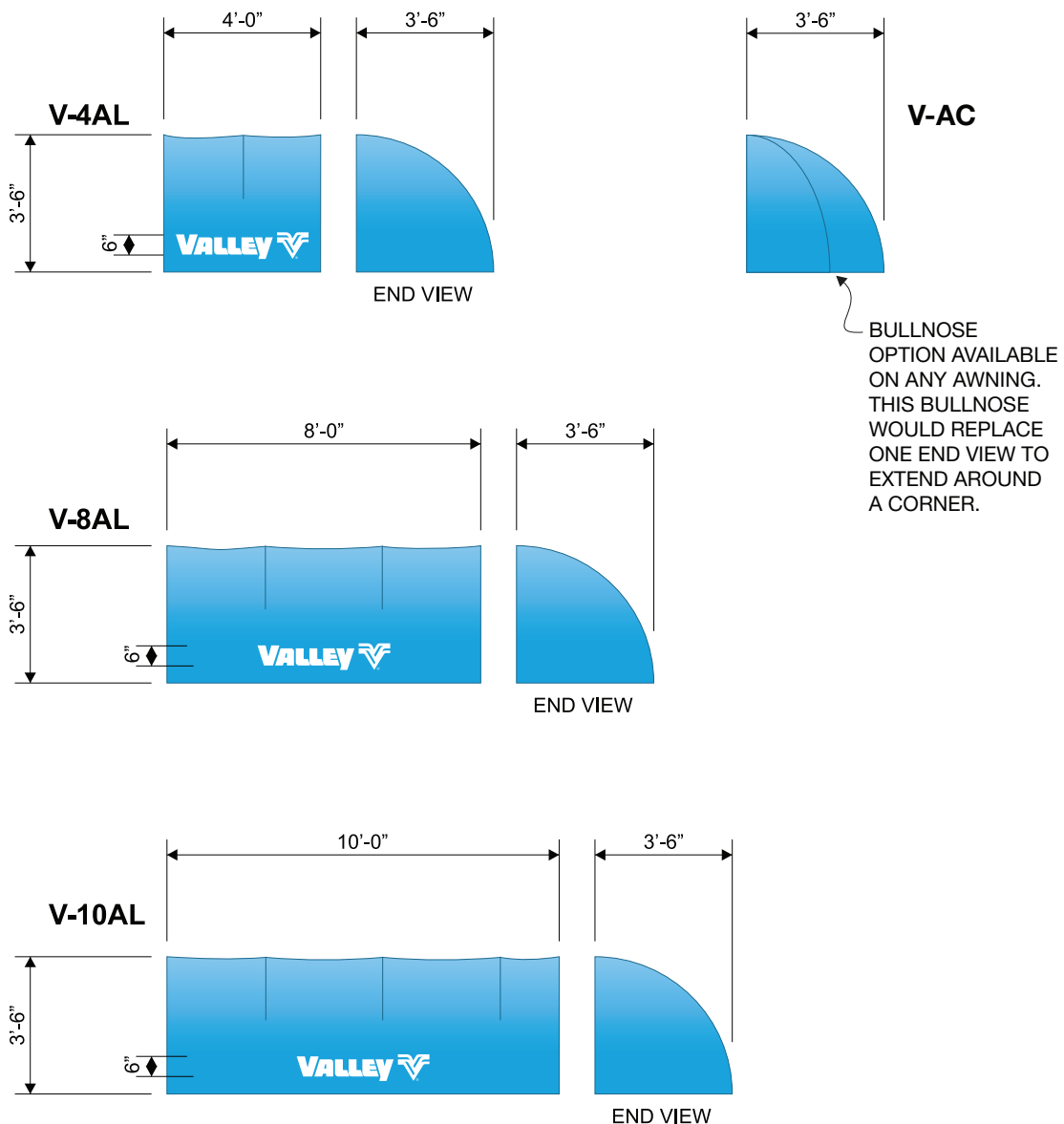

Awnings

Customized Dealer Identity Awnings

Your company identity may be added to the awning structure along with the Valley logo. Your company identity should be created using the standard corporate font recommended in this guide. Repeating your company identity or the Valley logo on each awning is not recommended.

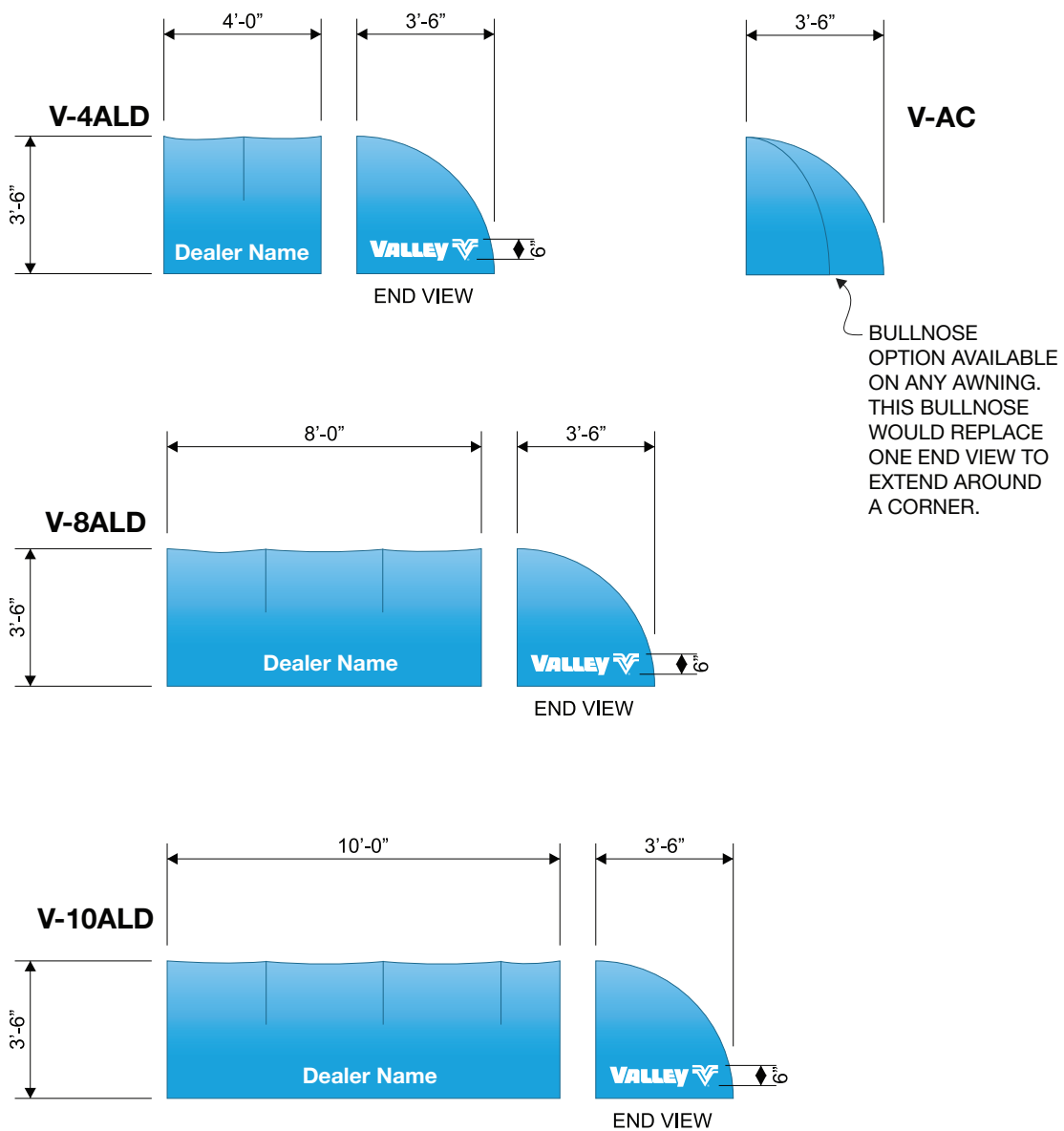

Vehicle Identification

Vehicles used for sales and service are a valuable tool for communicating the Valley brand. Vehicles that bear the Valley logo, type and dealer contact information should be properly maintained and cared for (showing no significant body damage) and cleaned regularly.

Order vehicle decals from valleystuff.net or download approved logos for printing at a local printer from valleyirrigation.com/brand.

Pickup Truck Horizontal Logo Usage

Vehicle logo branding is available in different configurations, depending on the vehicle type and size. Preferred logo usage is shown below and should comply with logo spacing and positioning (see page 17) for brand consistency.

- A Valley logo should be placed on the rear panel on each side of the vehicle as shown.
- The dealership name/logo and phone number are placed on the front door on both sides of the vehicle.
- Optional Valley logo placement on the hood and tailgate of the vehicle, in addition to the web URL, are included in the illustrations shown.

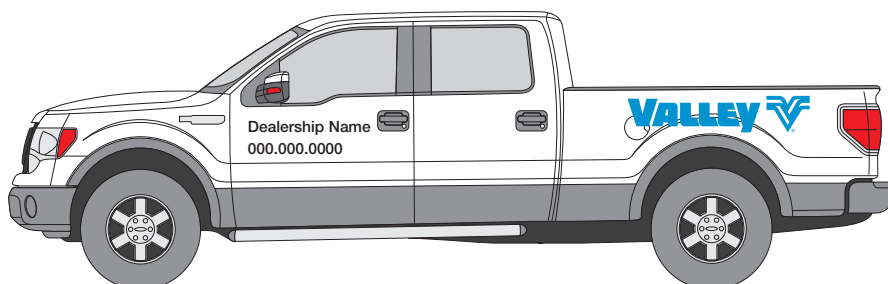
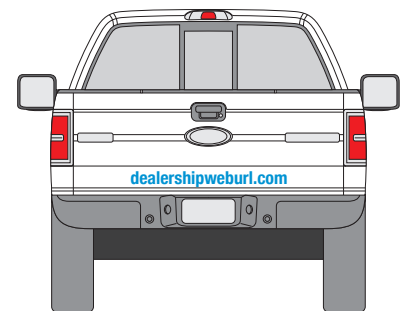
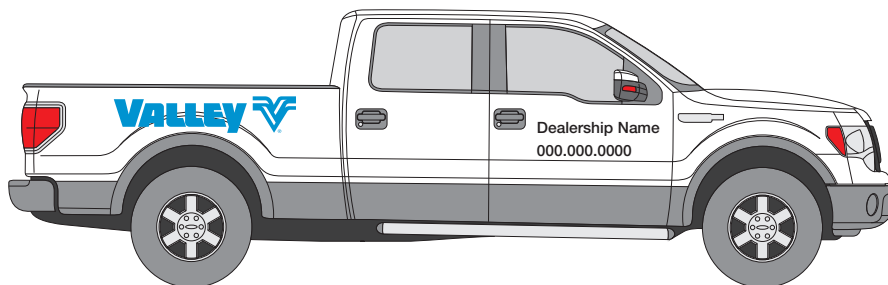

Vehicle Identification

Pickup Truck Vertical Logo Usage with Dealership Logo

Vehicle logo branding is available in different configurations, depending on the vehicle type and size. Preferred logo usage is shown below and should comply with logo spacing and positioning (see page 17) for brand consistency.

- A Valley logo should be placed on the second door on each side of the vehicle as shown.
- The dealership logo is placed on the front door on both sides of the vehicle. The dealership name and phone number are placed on the rear panel on both sides of the vehicle.
- Optional Dealer logo placement on the hood and Valley logo on the tailgate of the vehicle, in addition to the web URL, are included in the illustrations shown.

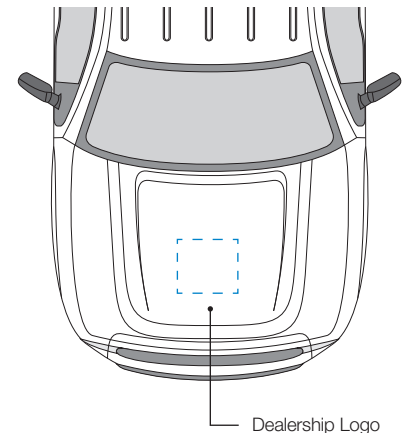
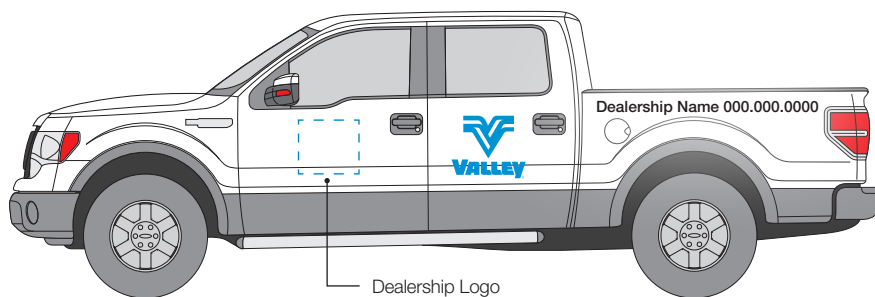
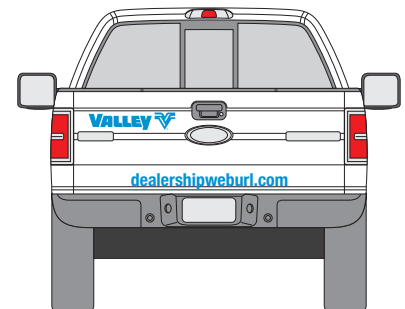
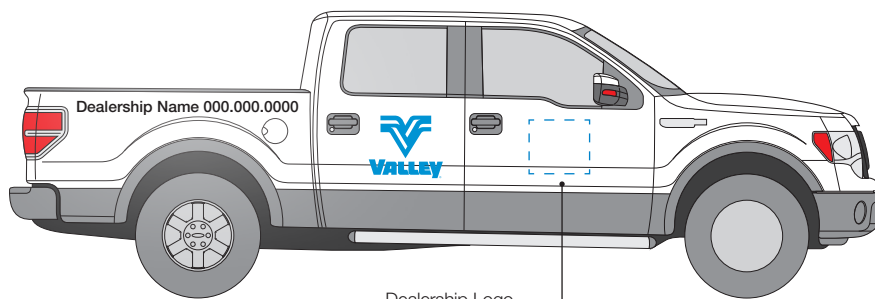

Vehicle Identification

Vehicle logo branding is available in different configurations, depending on the vehicle type and size. Preferred logo usage is shown below and should comply with logo spacing and positioning (see page 17) for brand consistency.

Service Truck Horizontal Logo Usage

- A Valley logo should be placed on the rear panel on each side of the vehicle as shown.
- The dealership name/logo and phone number are placed on the front door on both sides of the vehicle.
- Optional Valley logo placement on the hood and tailgate of the vehicle, in addition to the web URL, are included in the illustrations shown.

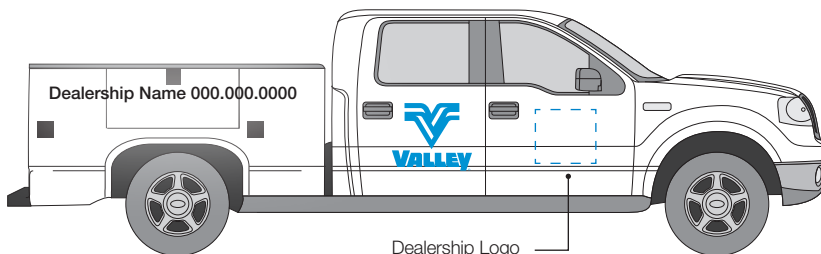
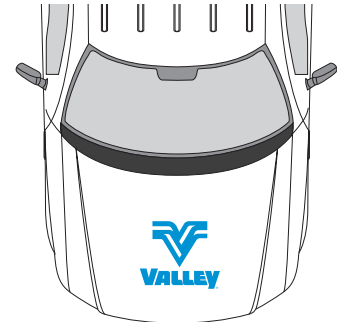
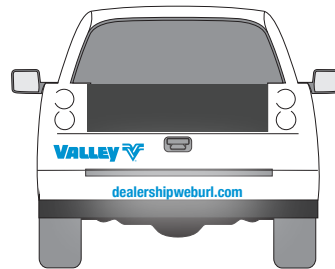
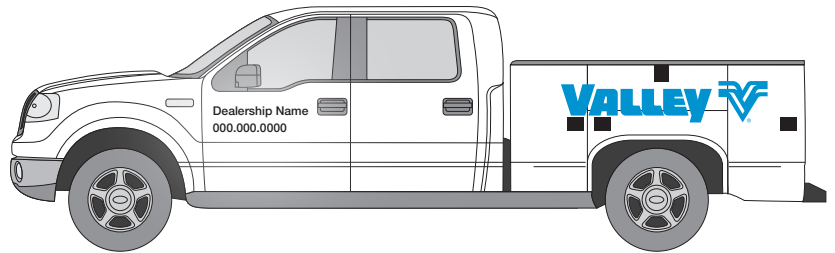
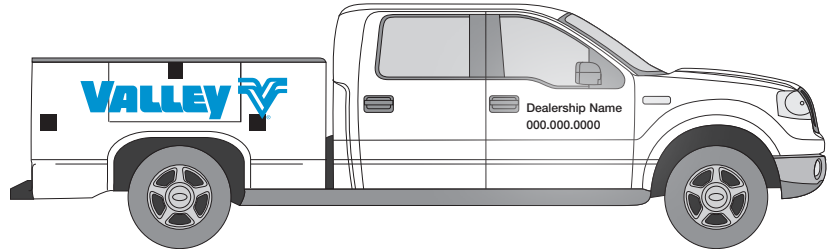

Dealership Logo

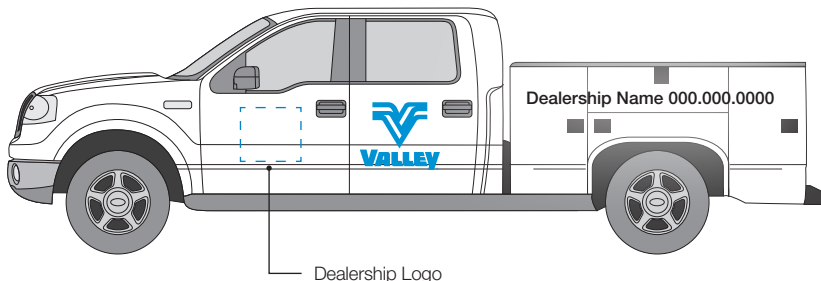

Dealership Logo

Service Truck Vertical Logo Usage

- A Valley logo should be placed on the second door on each side of the vehicle as shown.
- The dealership logo is placed on the front door on both sides of the vehicle. The dealership name and phone number are placed on the rear panel on both sides of the vehicle.
- Optional Valley logo placement on the hood and tailgate of the vehicle, in addition to the web URL, are included in the illustrations above.

Vehicle Identification

Service Truck Custom Graphic

Vehicle logo branding is available in different configurations, depending on the vehicle type and size. Preferred logo usage is shown below and should comply with logo spacing and positioning (see page 17) for brand consistency.

- The dealership logo is placed on the front door on both sides of the vehicle.
- A Valley blue bar graphic can be used on vehicles with reverse type phone number and reverse Valley logo on the sides
- A blue bar graphic with the web URL in reverse type can be placed on the rear tailgate.

Contact the Strategic Marketing Team for assistance and approval prior to production of customized vehicle graphics.

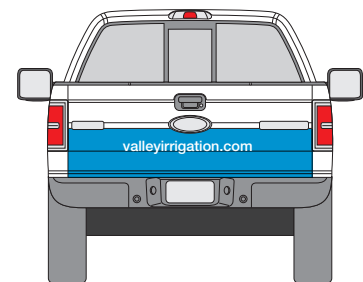
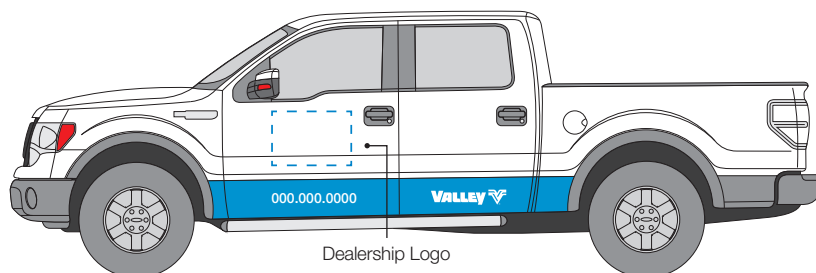
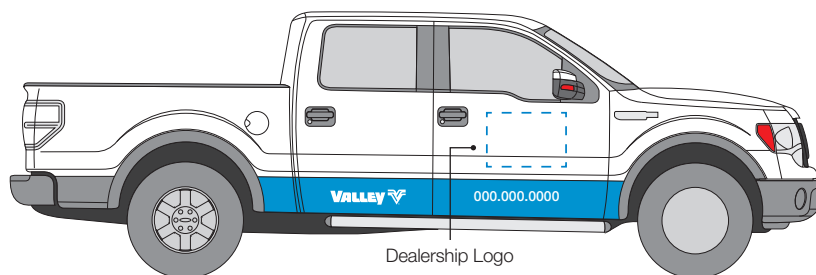
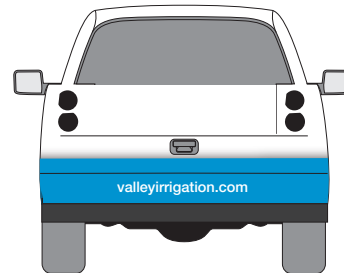
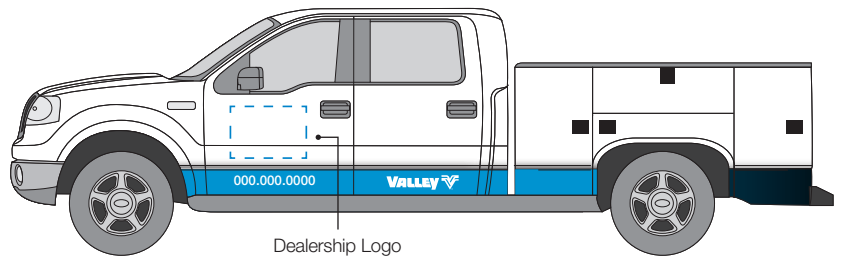
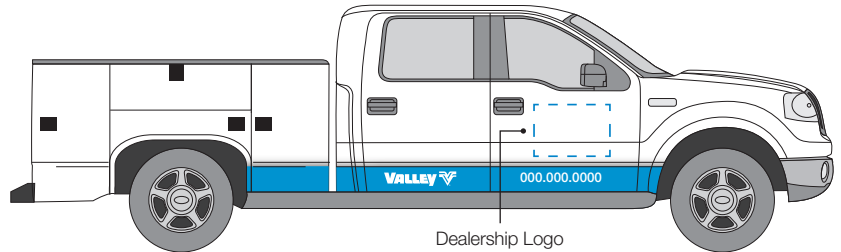

In-Store Retail Signage

Valley in-store retail signage is designed to effectively support the brand and enhance the customer experience. Maintaining your retail signage is critical, providing continuity in the Valley brand throughout all dealer locations and preventing brand confusion. It is important that all in-store retail signage is current and corresponds with the latest product/service it is intended to support.

Store signage hardware and printed materials can be ordered from valleystuff.net.

If you are ordering outside the U.S., please work with a local vendor to have the signage created. Contact the Strategic Marketing Team if you have questions.

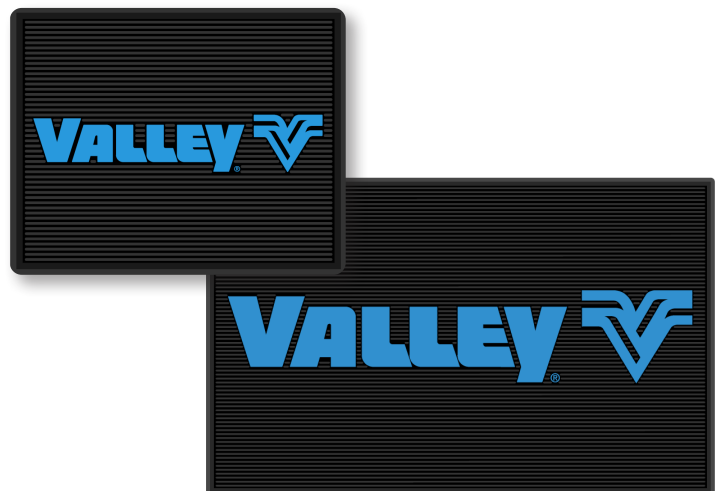

Flag Display Policy & Ordering

Showing national and company pride is consistent with our core values and something that many of our facilities around the world do through the display of flags. In an effort to provide guidance and consistency across our facilities, please adhere to this flag policy.

Number of Flags:

Each Valmont facility will have flags flying near the front of the facility as follows:

- Non-U.S. facilities will fly three flags, each on their own pole, flying in this order: 1. The national flag of the home nation. 2. The United States flag. 3. The Valmont corporate flag.
- U.S. facilities will fly two flags, each on their own pole, flying in this order: 1. The United States flag. 2. The Valmont corporate flag/logo. If a U.S. facility has three flag poles, a state flag may be added, following this order: 1. The United States flag. 2. The flag from the state where the facility is located. 3. The Valmont corporate flag/logo.
- Facilities with more flag poles than noted above will fly Valmont flags on those poles. Exceptions can be made when a facility has foreign visitors. In those cases, the flag of the visitor's country can be flown on the extra pole as a sign of welcome and respect.

Position of Flags:

The general rule for positioning flags is to start with the highest-ranking flag on the right-most pole. Then, move left in order of flag importance. To determine which pole is on the right, stand with your back to your facility while facing your flag poles. The one on your right is the right-most pole. To double check this, make sure that the same pole is also the left-most pole for visitors approaching the facility.

- For non-U.S. facilities, the order of these flags should comply with local customs. If local customs are unclear, fly the national flag of the home nation in the position of prominence (right to left as noted above), followed by the U.S. flag, followed by the Valmont flag. No one nation's flag should fly higher than any other during peacetime.
- All U.S. facilities will fly the U.S. flag in the right-most position (right to left as noted above) with a state or Valmont corporate flag to its left.
- The exception to the rule above is if you have one flag pole that is taller—usually centered between two others. In that case, the flag of prominence will fly on the tallest pole. The second-most prominent flag will fly to its right (use guide above to determine which is the right pole) and the third-most prominent to its left.

Exception for Flags

When applying the Valmont logo on flags, the registration mark ® is not used. Contact the Valmont Strategic Marketing Team at brand@valmont.com to request an approved logo for use on flags. Modifying a logo file, or asking a vendor to do so, is not permitted.

Sizing and Condition of Flags:

- All national flags displayed should be the same size.
- The Valmont® corporate flag will be the same size or smaller than the national flags. It cannot be larger.
- All flags must be clean and free from any rips, tears, fading, stains or other signs of disrepair.
- New flags must be ordered immediately (see below) once signs of wear are noticed.
- Flags that can no longer be flown must be disposed of in keeping with the customs of the country that flag represents.

Displaying Flags:

- All flags should be raised after sunrise and lowered before sunset unless each flag is illuminated.
- Company flags flown at Valmont® facilities will only contain the Valmont logo. This is true regardless of the facility name, its primary manufacturing focus or location.

Ordering Flags:

In order to maintain the same look and quality of flags, please purchase Valmont company and country flags directly from our preferred flag supplier:

Contact: Scott Kesick

scott@allflagsetc.com

P: +1 800.798.4520

All Flags, Etc.

14225 Dayton Circle, Suite 11

Omaha, NE 68137 USA

There are two sizes of Valmont and country flags available. Please pick the size that best suits your flag pole and ensure it is not larger than the other flags you are flying:

- 46" Flag - 4' X 6'
- 58" Flag - 5' X 8'

Also, be sure to check international shipping rates. In some cases, it might make sense to order extra or multiple flags in the same order to manage shipping costs.

06

**PRODUCT
LITERATURE**

VALLEY. IRRIGATION BRAND GUIDELINES

Literature

Consistent brand messaging can be seen across the available brand literature. The literature is designed so that individual products can be quickly identified and recognized by customers.

Product brochures, grower profiles and one-sheets can be ordered from valleystuff.net.

Dealers should stock only literature with this current look and feel. Digital versions of the literature can be found on Showpad, or on valleyirrigation.com under Resources.

If you are ordering outside the U.S., please work with a local vendor to have the literature created – literature files can be found on Product Library or work with your regional Marketing team members.

Brochures

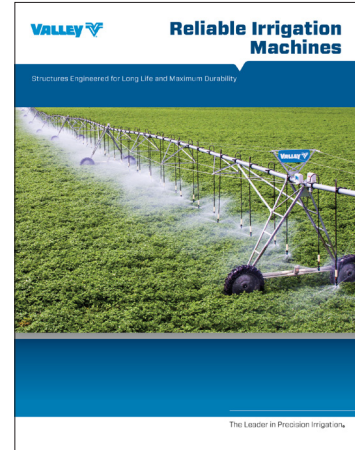
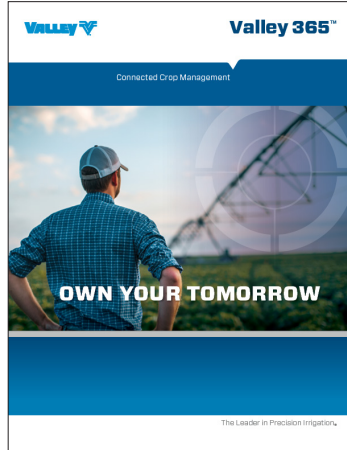

Grower Profiles

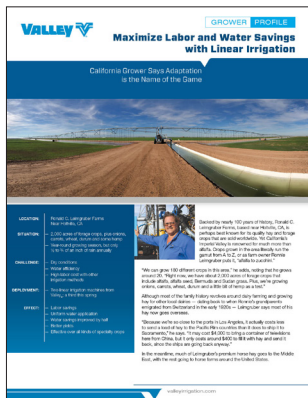

One-Sheets

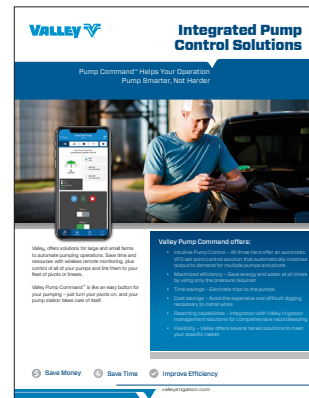

07

**DIGITAL
GUIDELINES**

VALLEY. IRRIGATION BRAND GUIDELINES

Valley Dealer Social Media Guidelines

Many dealers are taking advantage of social media as a way to promote their store and brand. However, all Valley Dealers must adhere to the following guidelines when using or mentioning the Valley brand.

1. Should you decide to use a the Valley brand within your social media channels, please ensure that you utilize the Valley Dealer logo provided here, rather than the official Valley logo.
2. Dealers are encouraged to share Valley content on their social media channels.
 - Videos – Either reshare videos posted on Valley social media channels or locate the video on the Valley Irrigation YouTube channel and share the link. Video files provided by Valley may not be uploaded directly to your social media channel.
 - Photos – Photos may be directly uploaded and shared on social media, but they each must include the following disclaimer: “© 2021 Valmont Industries, Inc.”
3. The dealer may not speak poorly or slanderously on their social media channel of Valley, Valmont Irrigation or any Valmont Industries brand.
4. Content you post or engage with should not be violent, sexually explicit, drug related, discriminatory or unlawful in any way. Ensure that your online profile is consistent with how you wish to present yourself to customers and colleagues. When you are online, you are representing Valley. Avoid engaging in bigotry, prejudice, misogyny, or hatred on your social media feed.
5. Should the dealer be presented with a Valley Dealer Performance Program designation the following requirements must be taken into consideration.
 - Use the correct and most up-to-date Performance Program designation logo that matches your designation. You can find the logo on V2O under Resources.
 - The logo may not be distorted or altered in any way.
6. Should the dealer either elect to stop selling Valley brand equipment or be let go by Valmont Irrigation as a Valley Dealer, the dealer must take down any branding, photos, videos or posts mentioning Valley or any Valmont brand within 24 hours of the contract ending.
7. Do not post anything showing, explaining or documenting dealer or sales meetings. These photos can be damaging to the Valley brand as customers may view them as flaunting or extraneous spending.
8. Dealers may use whichever of the social channels below that they feel are a good fit for their business. The official social channels for Valley include:
 - Facebook
 - YouTube
 - LinkedIn
 - Instagram

For more information view the complete Valmont Social Media Recommendations at <https://www.valmont.com/brand#social>

Social Media Policy

We would like to encourage employees to consider the consequences of your words before posting online. When Valley is connected to an employee's social media (i.e., listed as an employer), the employee needs to follow our Code of Conduct and confidentiality policies. In an effort to avoid problems and misunderstandings, Valley has established a few recommendations to provide helpful and practical advice for social media use.

- Follow our company's policies and abide by our core values. Online activity that violates the company's Code of Conduct may subject an employee to disciplinary action, including termination.
- Ensure that your online profile is consistent with how you wish to present yourself to customers and colleagues. When you are online, you are representing our people and our values. Avoid engaging in bigotry, prejudice, misogyny or hatred on your social media feed.
- Do not use ethnic slurs, personal insults, obscenity, or engage in any conduct that would not be acceptable in the workplace. Show proper consideration for others' privacy and for topics that are objectionable or inflammatory.
- Do not discuss or post any confidential information on any social platforms. If a document or item features the sentence "for internal use only," then it is not meant to be forwarded to anyone who is not employed by Valley. Please act responsibly with entrusted information.
- Content you post or engage with should not be violent, sexually explicit, drug-related, discriminatory or unlawful in any way. Non-public financial or operational information about Valmont should not be discussed or shared.
- Follow and engage with the official Valley social media channels
 - i. Facebook: <https://www.facebook.com/ValleyIrrigationUSCA>
 - ii. Instagram: <https://www.instagram.com/valleyirrigation/>
 - iii. LinkedIn: <https://www.linkedin.com/company/valley-irrigation/>
 - iv. YouTube: <https://www.youtube.com/user/ValleyIrrigation>

To learn more, download our Code of Conduct in your preferred language:
www.valmont.com/about-us/code-of-business-conduct

Posting to Social Media

Strategic Marketing recommends the following frequency for posting to social media networks, so as not to overwhelm followers and create a negative brand image. If the minimum recommendations are too frequent for your brand or office to keep up with, we recommend not creating a social media presence until resources can be dedicated to keep up with the frequency.

- Facebook – post a minimum of two times per week and a maximum of twice per day
- Twitter – post a minimum of three times per week and a maximum of once per hour
- YouTube – post a minimum of one time per month and maximum of one time per week
- LinkedIn – post only business/industry-related content maximum of once per day
- Instagram - post a minimum of two times per week

Dealer Website Guidelines

A clean, functional and informative website is a must for modern businesses. Consumers now search for products and services almost exclusively on the internet. Valley Strategic Marketing has resources to help you establish a web presence. Of course, you may also use a local vendor you are familiar with.

There are several important guidelines to keep in mind while developing your website.

- Don't use a URL (web address) with "Valley" in it. Doing so waters down the Valley brand and can confuse customers.
- Do not simply copy the valleyirrigation.com website look and feel. Your website should be your own; once again, this can confuse customers and damage our brand integrity.
- Furthermore, don't just copy descriptions of our products and solutions; change the wording enough to keep the same message but not be a straight duplication. Search engine algorithms are now smart enough that they can detect when multiple websites use the same text, and often penalize them in search results. This hampers customers' ability to find your site – and ours.
- Optional pre-approved template options are available. For template options for your dealership to use, please contact the Valley Marketing Team at valleymarketing@valmont.com. Part of the cost of starting a new website may be eligible for co-op reimbursement.

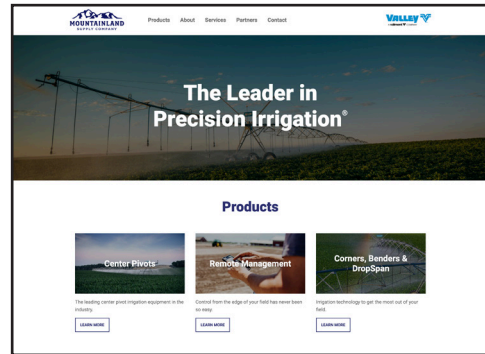

Protecting the Valley Brand Name

Protecting our brand while ensuring each dealership has their own complementary brand is a balance. Your dealership is a part of Valley, but should not mirror our branding so closely that customers could be confused about which is the parent company. For example, dealers should not name their dealership "Valley Chile" and have a URL (such as valleyirrigationchile.com) that is similar to ours: www.valleyirrigation.com.

NOTE: We do realize that some of you are in areas or towns with Valley in the name, such as "Central Valley." In these cases, please consult with Marketing to assure brand autonomy.

08

**PUBLIC
RELATIONS**

VALLEY. IRRIGATION BRAND GUIDELINES

Public Relations

There are four key reasons for developing good relationships with members of the media:

- You can generate third-party credibility and implied endorsement of your product or business.
- You can use relationships with the media and subsequent placement of stories to position your company as an authority, and to build your image and reputation.
- Through stories in the media, your messages will reach current and potential customers, influencers and decision makers.
- Building relationships in good times helps protect you and your business in bad times.

Preparing Press Releases

Press releases inform the media about your news and events. Press releases are essentially short articles you write and send to media outlets. The exposure is free if a media outlet chooses to use it.

Tips for writing a press release:

- Make sure the information you are writing about is really newsworthy.
- Reporters decide quickly whether a release is newsworthy, so include the most important information (who, what, where, when, how and why) in the first couple of paragraphs.
- Keep the release short – no more than two pages.
- Always include a contact name and number, in case the reporter wants more information.
- A news release template – with standard formatting – is included in this book.

Tips for sending a press release:

Call your targeted media outlets to find out:

- How they want the release sent (e.g., email, fax)
- Who to send the release to
- The deadlines for submission
- The desired lead time for an event (generally two or three weeks for a newspaper)

There is much debate on the best day of the week and the best time of day to send a news release. You may choose to use the outlets' deadlines (or specific advice) as your guide. The Valley Marketing Team usually sends its press releases in the morning, on Tuesdays, Wednesdays or Thursdays. DO NOT send news releases on Fridays.

Press Release Template

A standardized Valley press release template has been created to help you craft your press releases. To create a consistent and trustworthy image of the Valley brand, it is vital to achieve a high level of recognition and standards by sharing common communication methods. This Press Release template is mandatory for Valmont employees. Valley dealers are not required to use this template.

Download the approved template from valleyirrigation.com/brand. Please send all press releases through Valley Strategic Marketing for approval.

Press Release



A valmont COMPANY

FOR IMMEDIATE RELEASE

Contact: [Contact Name]
Phone: [Contact Phone Number]
Date: [Date of Release: Month d, yyyy]

[Press Release Title Here]

[Content here]

About Valley Irrigation
 Valley® Irrigation founded the center pivot irrigation industry in 1954, and our brand is the worldwide leader in sales, service, quality and innovation. With historical sales of more than 250,000 center pivots and linears, Valmont-built equipment annually irrigates approximately 25 million acres (10 million hectares) around the world. We remain dedicated to providing innovative, precision irrigation solutions now and into the future. For more information, please visit valleyirrigation.com.

About Valmont Industries, Inc.
 Valmont® is a global leader, designing and manufacturing engineered products that support global infrastructure development and agricultural productivity. Its products for infrastructure serve highway, transportation, wireless communication, electric transmission, and industrial construction and energy markets. Its irrigation equipment and services for large-scale agriculture improve farm productivity while conserving fresh water resources. In addition, Valmont provides coatings services that protect against corrosion and improve the service life of steel and other metal products. For more information, visit valmont.com.

Story Pitches & Media Alerts

Story Pitches

A story pitch is a quick way to notify a reporter of a potential story idea.

- Make sure your idea is newsworthy. Ask yourself, "Why would a reader care about this? Is it interesting, timely, new, useful or unique?".
- Do not pitch the same story to competing news outlets at the same time.
- Story pitches are most successful when you already have a relationship with a reporter or assignment editor.
- Pitches can be made by phone or email.

If you call:

- Introduce yourself, tell the reporter you have a story idea and ask if he/she has a moment to talk.
- Give them a brief explanation of your idea, including the basic facts: who, what, when, where and why.
- Ask them how they would like you to follow up.

If you email:

- Keep it brief.
- Explain your story idea and describe its relevance to readers.
- Provide pertinent dates, times and background.
- Provide your contact information.

Media Alerts

A media alert is a specific tool designed to let the media know about an event that will generate news. Often an alert provides enough information to arouse interest without completely revealing the story. An alert should include concise information:

- Who is involved, including: speakers, key attendees or who is invited?
- Why it is important?
- What the event is?
- Where it is, including location and directions?
- When it is, including the date and time?

Media Alert Template

A standardized Valley media alert template has been created to help you provide information to media outlets quickly. This Media Alert template is mandatory for Valmont employees. Valley dealers are not required to use this template.

Download the approved template from valleyirrigation.com/brand.

Media Alert



A valmont COMPANY

[Insert Headline Here]

What: [Content here]
When: [Content here]
Where: [Content here]
Who: [Content here]

[Content here]

Contact: *In advance of event for details and interview times.*
Your name here
Valmont Industries, Inc., title here
Email here
Phone number here

About Valley Irrigation
Valley® Irrigation founded the center pivot irrigation industry in 1954, and our brand is the worldwide leader in sales, service, quality and innovation. With historical sales of more than 250,000 center pivots and linears, Valmont-built equipment annually irrigates approximately 25 million acres (10 million hectares) around the world. We remain dedicated to providing innovative, precision irrigation solutions now and into the future. For more information, please visit valleyirrigation.com.

About Valmont Industries, Inc.
Valmont® is a global leader, designing and manufacturing engineered products that support global infrastructure development and agricultural productivity. Its products for infrastructure serve highway, transportation, wireless communication, electric transmission, and industrial construction and energy markets. Its irrigation equipment and services for large-scale agriculture improve farm productivity while conserving fresh water resources. In addition, Valmont provides coatings services that protect against corrosion and improve the service life of steel and other metal products. For more information, visit valmont.com.

09

CONCLUSION

VALLEY. IRRIGATION BRAND GUIDELINES

Brand Summary

Now it's up to each of us to make sure we stay "on brand." Following the guidelines is key to brand consistency. If there are further questions or a need for additional clarification, the user of these guidelines should contact the Strategic Marketing Team. There may be unique applications that warrant exception to one or more of these guidelines. In such cases, before implementation can proceed, a request must first be directed to the Strategic Marketing Team for review and resolution. Thanks in advance for your efforts and support of our brand and its integrity.

For more information and to answer any questions about the Valley brand, please contact valleybrand@valmont.com.