

REALIZE IMPROVED STRUCTURAL STRENGTH THROUGH FORGING

The custom manufactured SteelCOR® forged ring base plate is fast becoming the industry's preferred alternative to steel base plate construction to meet market demands and mitigate the risk of variable supply from traditional steel mills. SteelCOR custom manufactured base plates meet the range of thickness the market requires, yields greater strength, and reduces lead time through the advanced engineering from Valmont® Utility.

Tubular steel poles carry higher voltages, thus increasing the magnitude of the structure and in return increasing the size of base-plated designs. To meet the material standards required by the industry, thickness and widths are difficult to acquire. The call for large, thick base plates exceeds interest from the steel mills. This resistance to produce has initiated excessive lead times and posed danger of delaying project completion.



STRUCTURAL FORCE RINGS TRUE

- Performance has proven to meet or exceed that of traditional mill plate construction through established testing and development on material, weld and conditional exposure.
- Design flexibility includes rolled-to-size proficiency and CNC surface milling to establish a flat surface on the finished product.
- An environmentally sound solution with a rolled-to-size manufacture, eliminating the typical 40% scrap rate of conventional base plate technology.

STEELCOR DELIVERS

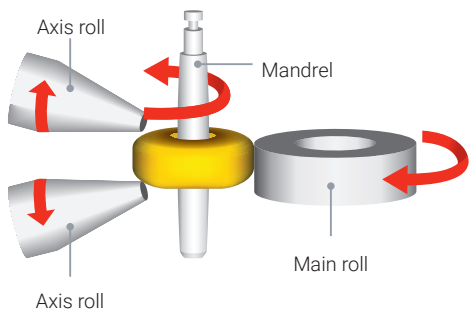

- Greater than 3" thick base plates. There is no upper thickness restriction, unlike conventional base plate technology.
- Circular grain structure eliminates directional grain concerns in plate product.
- Yield strength measures 60KSI versus the typical 50KSI plate.
- Provides a finished product for direct attachment to the pole shaft without finishing, bolt hole drilling or surface preparation.
- Quality assurance with mill analysis and test reports required for each piece. This includes analysis for:
 - Chemical composition of the material
 - Physical properties
 - Charpy testing
 - Corrosion resistance analysis per G101
 - Thru-thickness lamellar Ultrasonic Testing

COMPREHENSIVE TEST RESULTS

The current base plate design process utilized at Valmont is proven by use and validated by analysis and numerous full-scale tests. The custom manufacture, Valmont standard base plate allows for galvanizing drainage roughly in the shape of a diamond, encompassing approximately 30% of the area within the pole shaft base.

Traditional base plate designs were developed and analyzed using finite element methods to establish baseline data for the ring material sizing. The ring material was sized with varying sizes of internal circular cutout, analyzed and data points recorded. Based on these results, Valmont Utility developed a preliminary solution and performed full-scale testing using strain.

These results were then finalized and taken to an outside, independent source for review and validation – the Structural Engineering Department and laboratory at the University of Nebraska in Lincoln, NE. Their results and recommendations were considered and ultimately incorporated into the Valmont standard custom design procedure for SteelCOR forged rings.

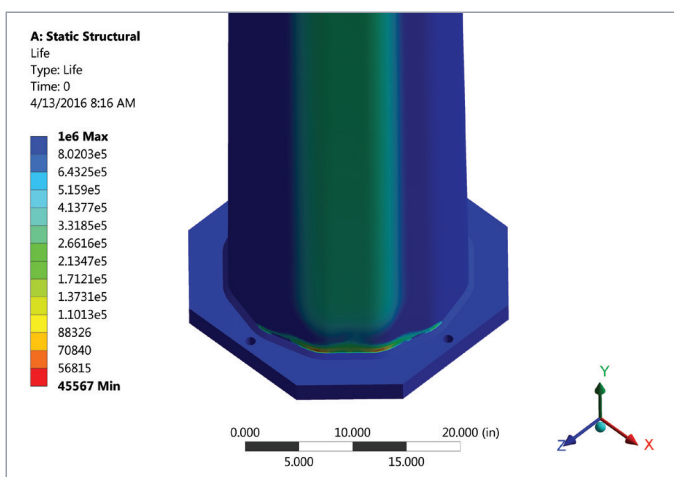
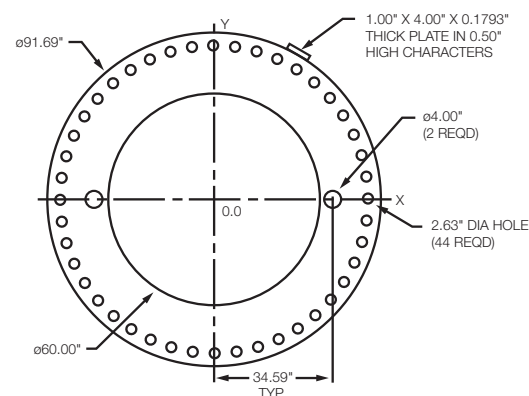
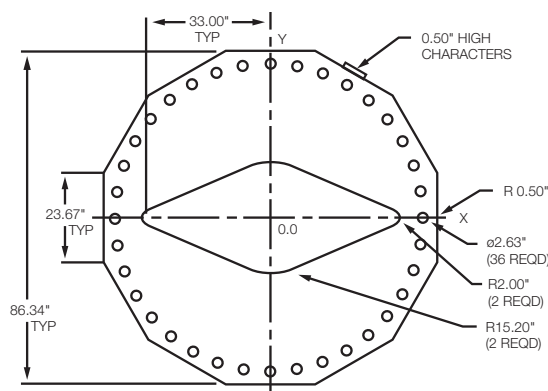

SteelCOR forged rings utilize the Valmont Utility process for adequately sizing the internal diameter of the ring. This is based on the ring material thickness and the pole shaft inside diameter (flat-to-flat), providing a structure of strength.

©2024 Valmont Industries, Inc. All rights reserved. Valmont Utility has a policy of continuous product improvement and development. As a result, certain changes in standard equipment, options, price, etc. may have occurred after the publication of this brochure. Some photographs and specifications may not be identical to current production. Valmont Utility reserves the right to change product design and specifications at any time without incurring obligations.